

Strategies in Car Body Engineering 2011

Process Chain „Painted Car Body“

How to cope with demands ...

... for

- lower cost and energy efficiency
- greater production flexibility
- better quality
- global availability

Dr. Hans Schumacher, Dr. Pavel Svejda, Dürr Systems

Bad Nauheim, 23.03.2011

Agenda

- **Market trends**
- **Process chain “painted car body”**
- **Solutions for more efficiency and sustainability in global car manufacturing**

Agenda

- **Market trends**
- Process chain “painted car body”
- Solutions for more efficiency and sustainability in global car manufacturing

Light Vehicle Production in Million Units

Emerging and established markets

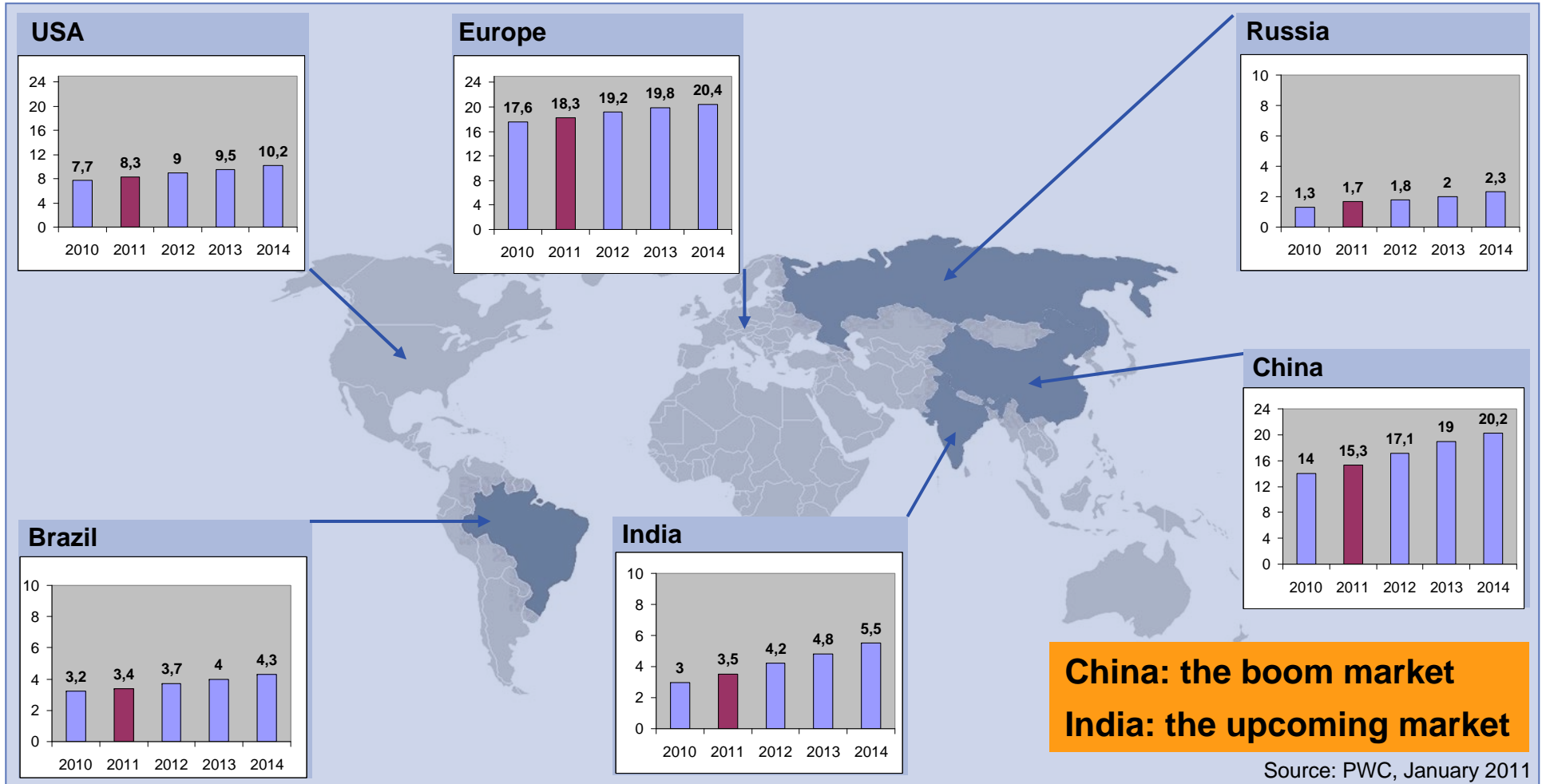

Sales Revenues & Employees in 2010:

**Sales revenues
2010 (2009)**

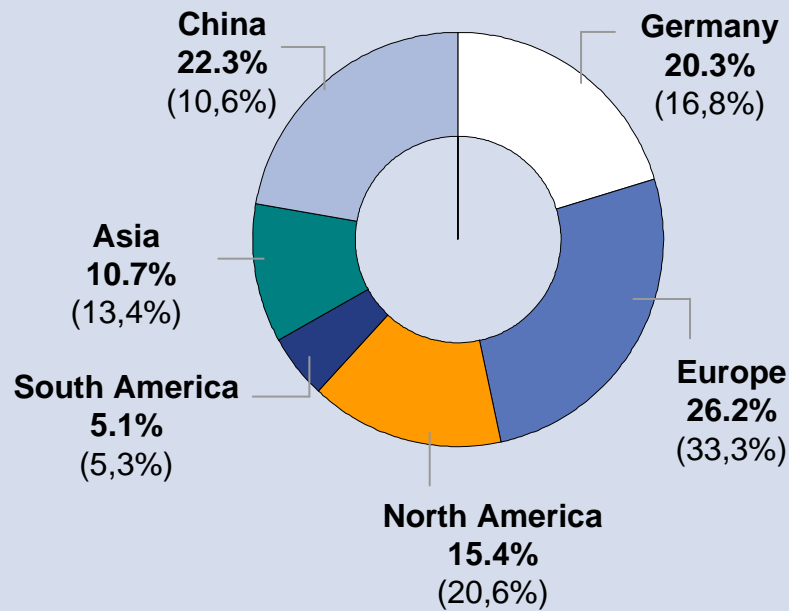

**Employees
2010 (2009)**

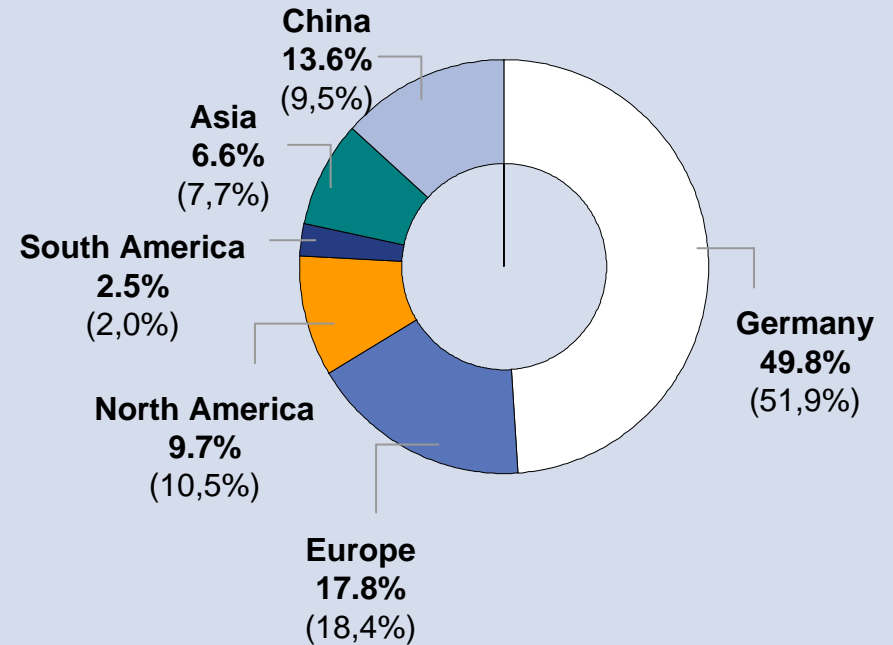

Focusing on growing markets in China and Asia

Agenda

- Market trends
- **Process chain “painted car body”**
- Solutions for more efficiency and sustainability in global car manufacturing

Process Chain “Painted Car Body”

Trends & influences

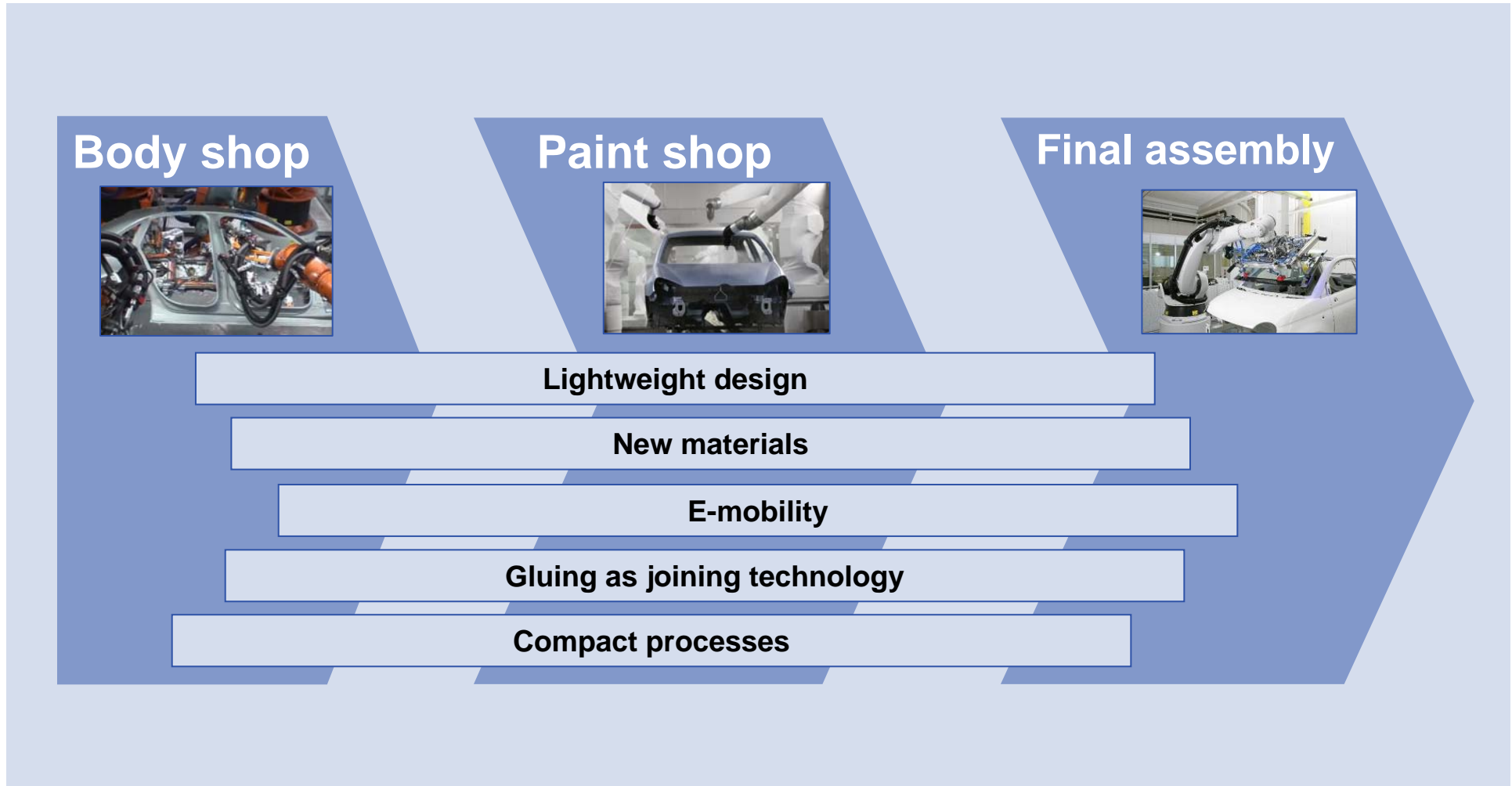

Process Chain “Painted Car Body”

Targets

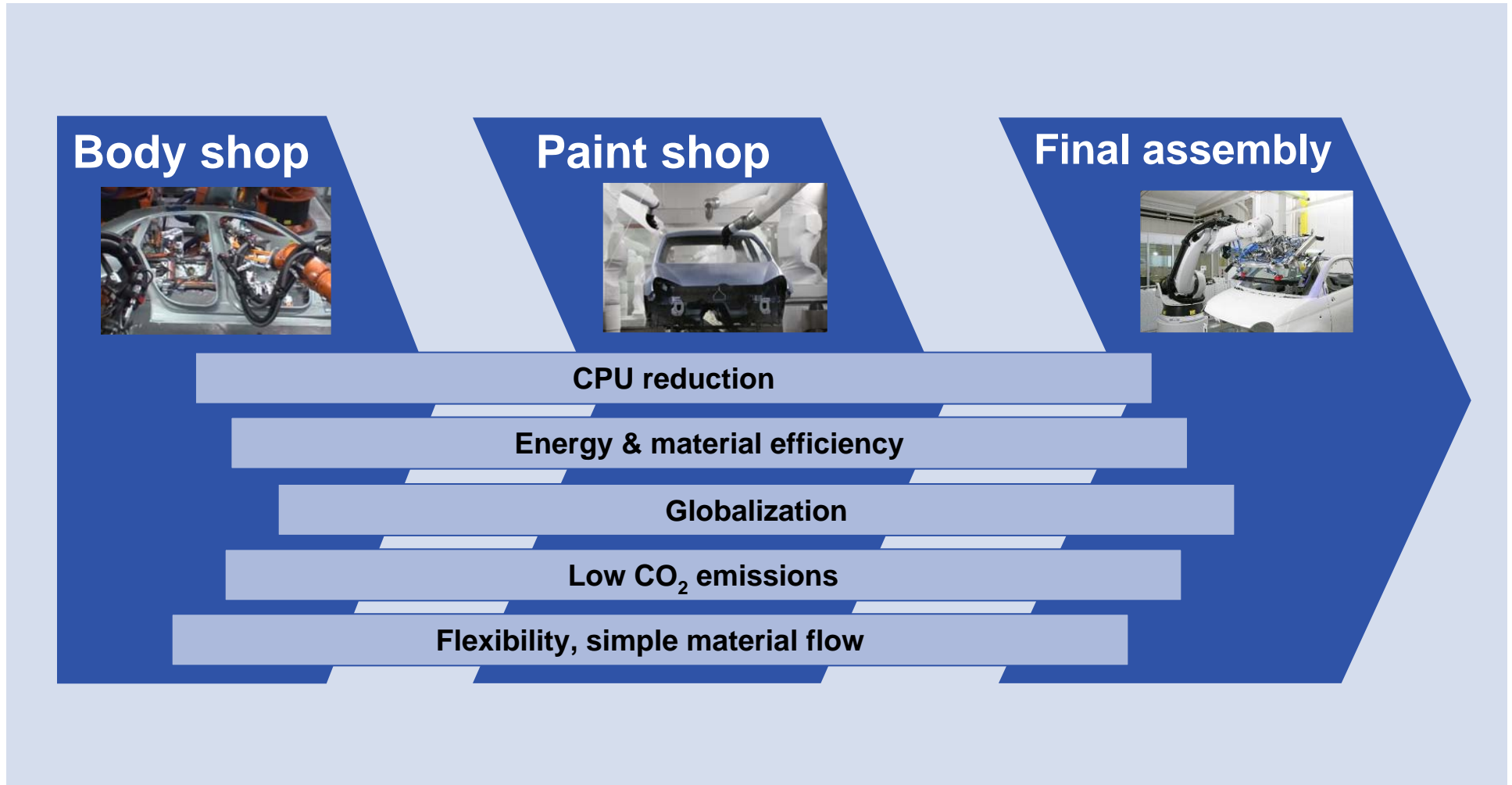

Agenda

- Market trends
- Process chain “painted car body”
- **Solutions for more efficiency and sustainability in global car manufacturing**

Possibilities for CPU Reduction

Example: Paint Shop

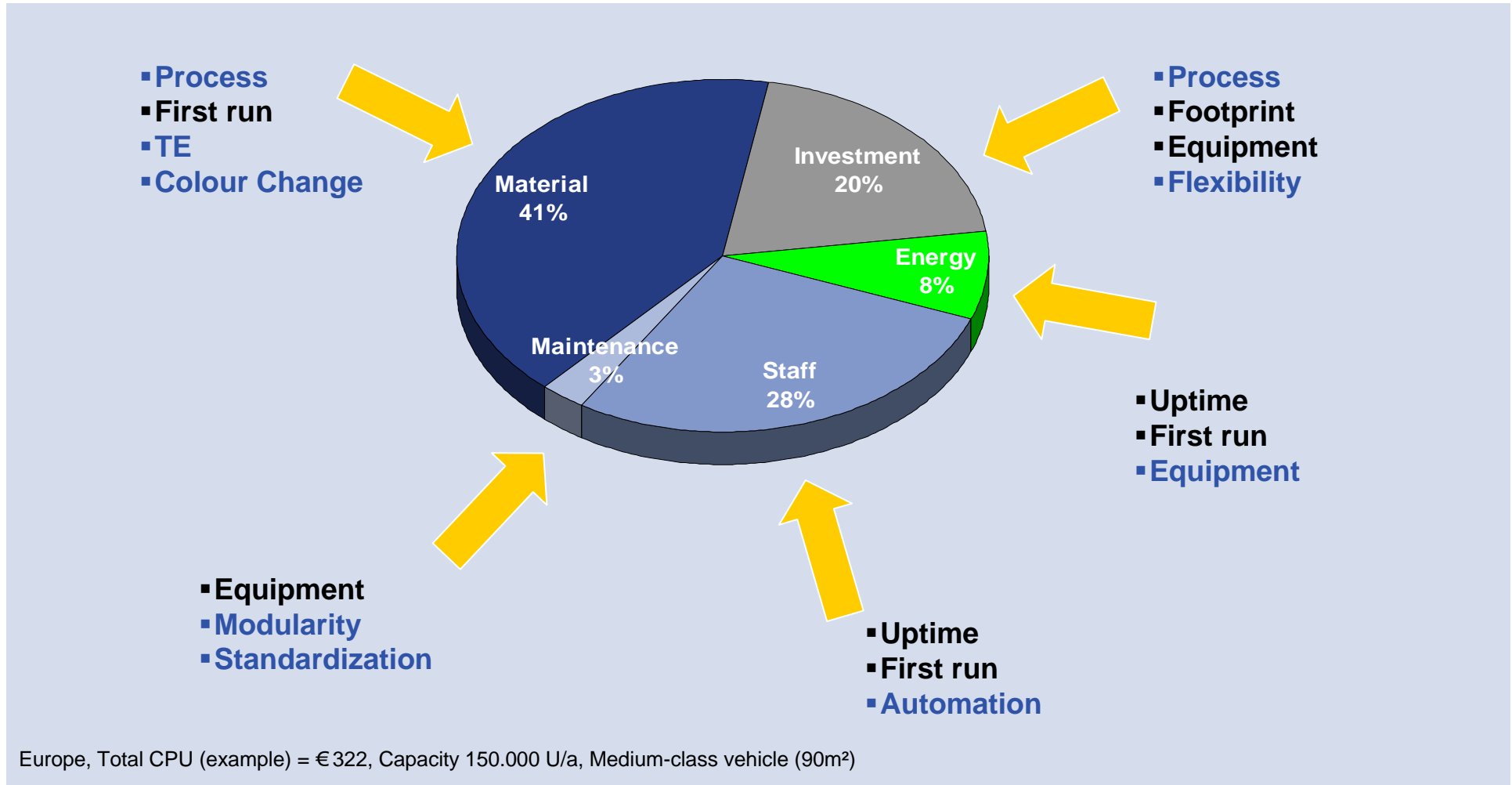

Compact Processes in the Paint Shop

Standard

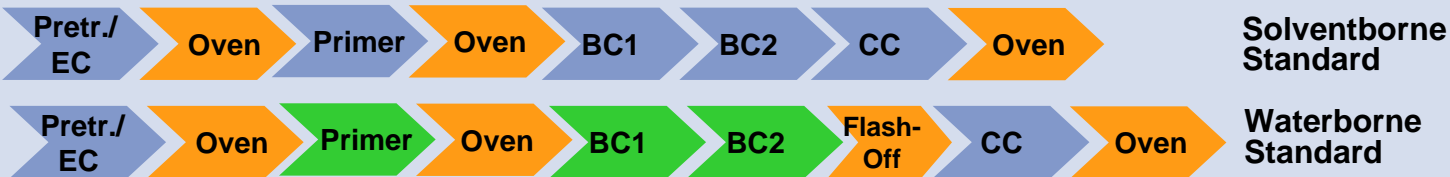

Compact

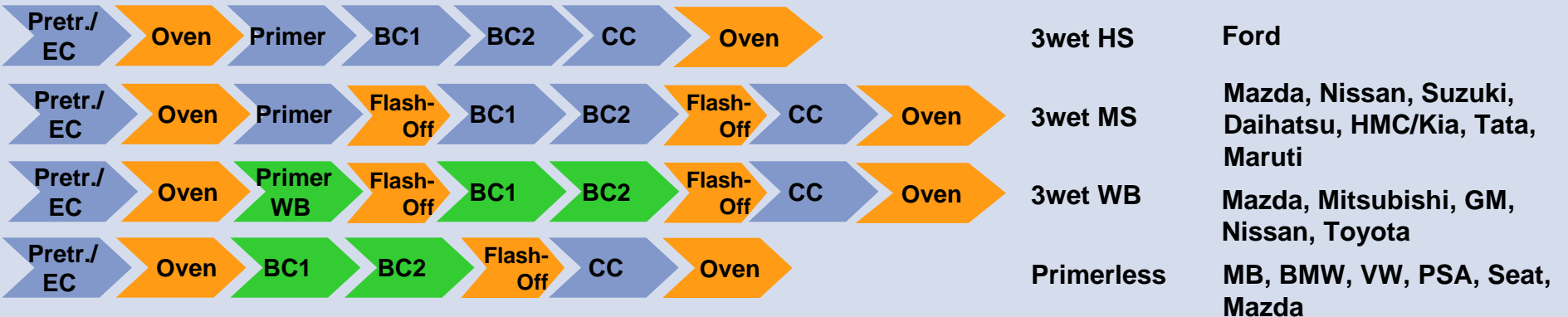

- Reducing footprint & investment
- Reducing energy consumption
- Offering opportunities for innovative layouts

Innovative Paint Booth Concept

EcoDryScrubber: Overspray dry separation



- CPU reduction: around 10 €per car body, energy savings up to 30%
- Dry overspray separation system for wet paints
- Automated separation of overspray without water and chemicals
- Effective recirculation of process air
- 35% reduced cross section

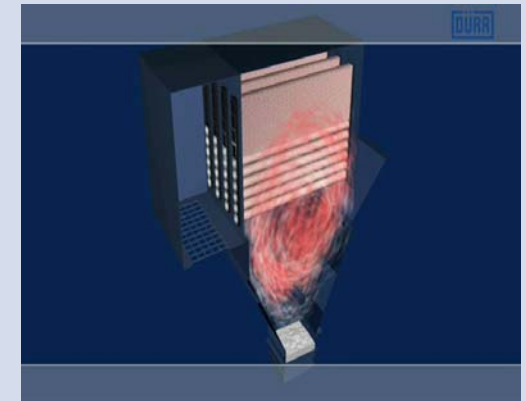

Orders received for already 36 paint lines, e.g. Daimler (Hungary), BMW (Germany), FAW/VW (China), Nissan (China), SGM (China), Chery (China), VW (USA), Rehau (Germany), Rehau (South Africa)

New Modular Layout Concepts (1)

Standard layout vs. modular shop

Standard Layout

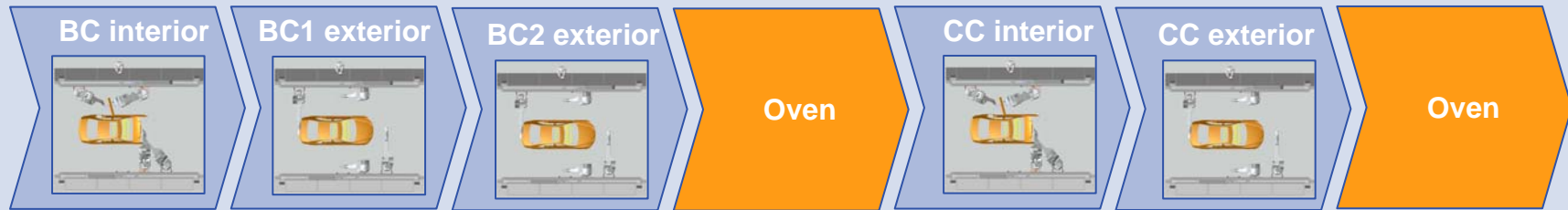

Modular Shop

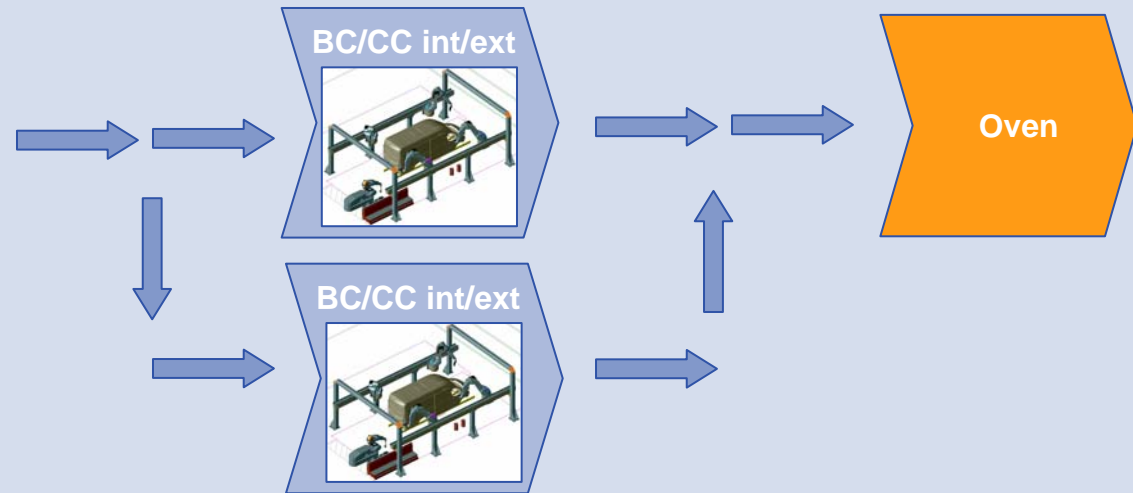
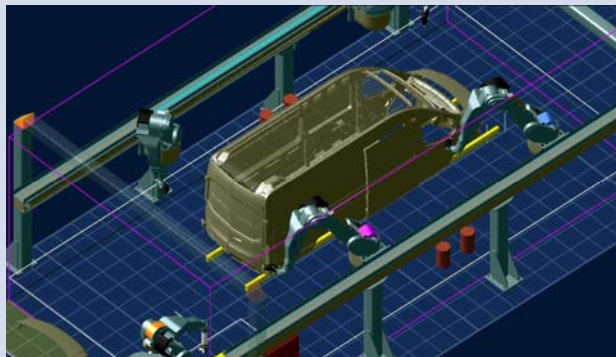

Modular shops: Highest production flexibility

New Modular Layout Concepts (2)

Standard layout vs. modular shop

Standard Layout



- High production volume
- Low model variety
- Constant cycle time
- Process dedicated application

Modular Shop

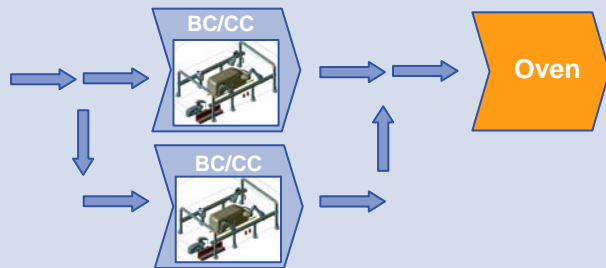

- Low production volume
- High model variety
- Model dedicated cycle time
- Same application for all processes

References: Porsche, Mercedes Benz, JMC
Key enabler: The new *EcoBell3* atomizer



Painting Robots

Example: *EcoLCC*, linear colour changer for lowest colour change losses

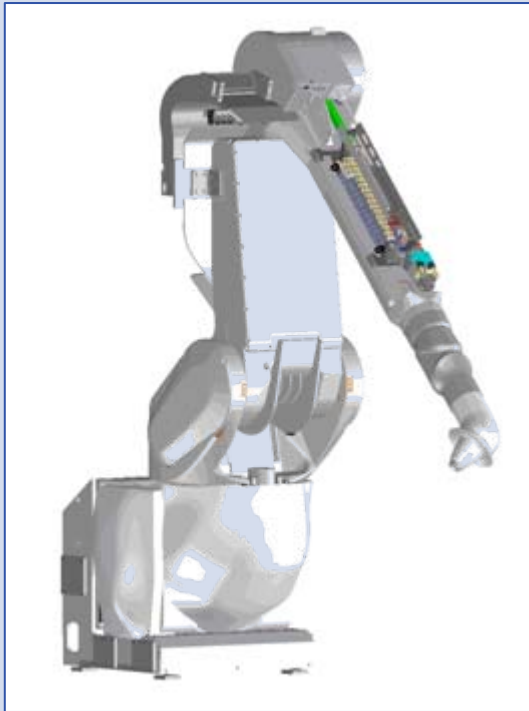

Today



Future



EcoLCC:

- Reduction of colour change losses up to 10 ml
- Omission of colour selection buffers possible

Sealing in Paint Shop

Common base for application equipment throughout the paint shop

- Automated process for long term corrosion protection guarantee
- Reducing material consumption by accurate and repeatable application process
- High system dynamics for higher productivity



***Ecopaint* Sealing: modular system for high quality and CPU reduction**

Global Solutions & Technology



Example: FAW-VW Chengdu, China & VW Chattanooga, USA

Common Solutions

- Layout
- PT/ED by rotational dipping
- Overspray dry separation for energy reduction
- Compact primerless process
- 100% automation for painting
- Colour change system with reduced paint loss (LCC)
- Contactless film thickness measuring system

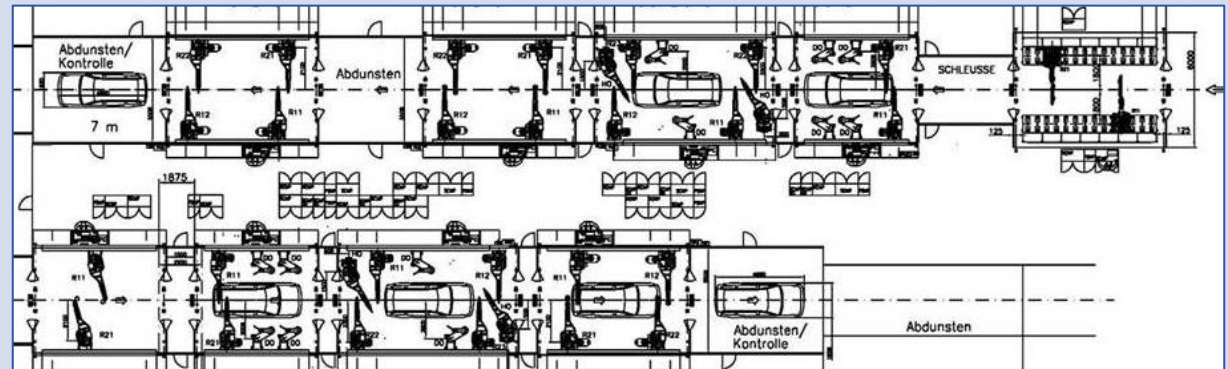
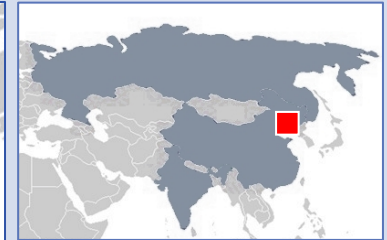

Same quality and product flexibility for all markets

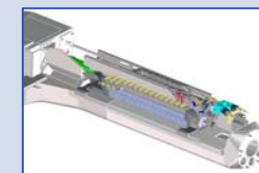

Global Solutions & Technology

Example: Ford Changan, China & Ford Rayong, Thailand

Common Solutions

- Basic Layout (1 line in Thailand, 2 lines in China)
- Compact 3wet high solid process
- Bell/Bell application for highest TE

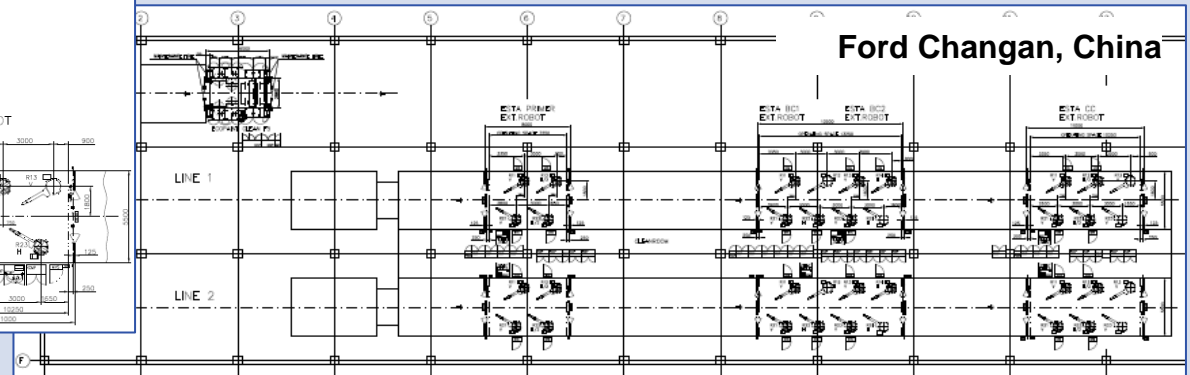
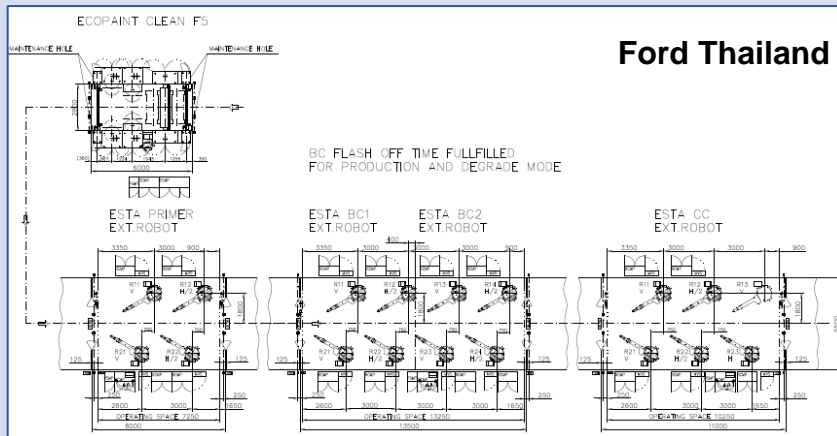
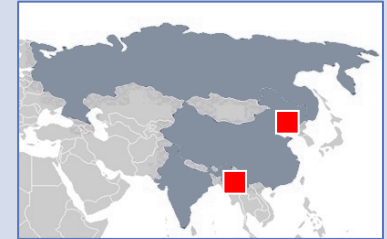

Same quality and product flexibility for all markets



Conclusion



Body shop



Paint shop



Final assembly



Global processes and technologies...

...guaranteeing quality, efficiency and sustainability.

R & D must be considered as a continuous process.