

Strategies in Car Body Painting 2010

Efficient Use of Energy and Resources

International Paint Processes and Paint Installations from the Perspective of a Paint Plant Manufacturer

Dr. Hans Schumacher, Dürr Systems

Berlin, 10./11. June 2010

Agenda



- **Global trends**
- **Actual examples**
- **Global solutions for efficient use of energy and resources**

- **Global trends**
- Actual examples
- Global solutions for efficient use of energy and resources

Light Vehicle Production in Million Units

Emerging and established markets

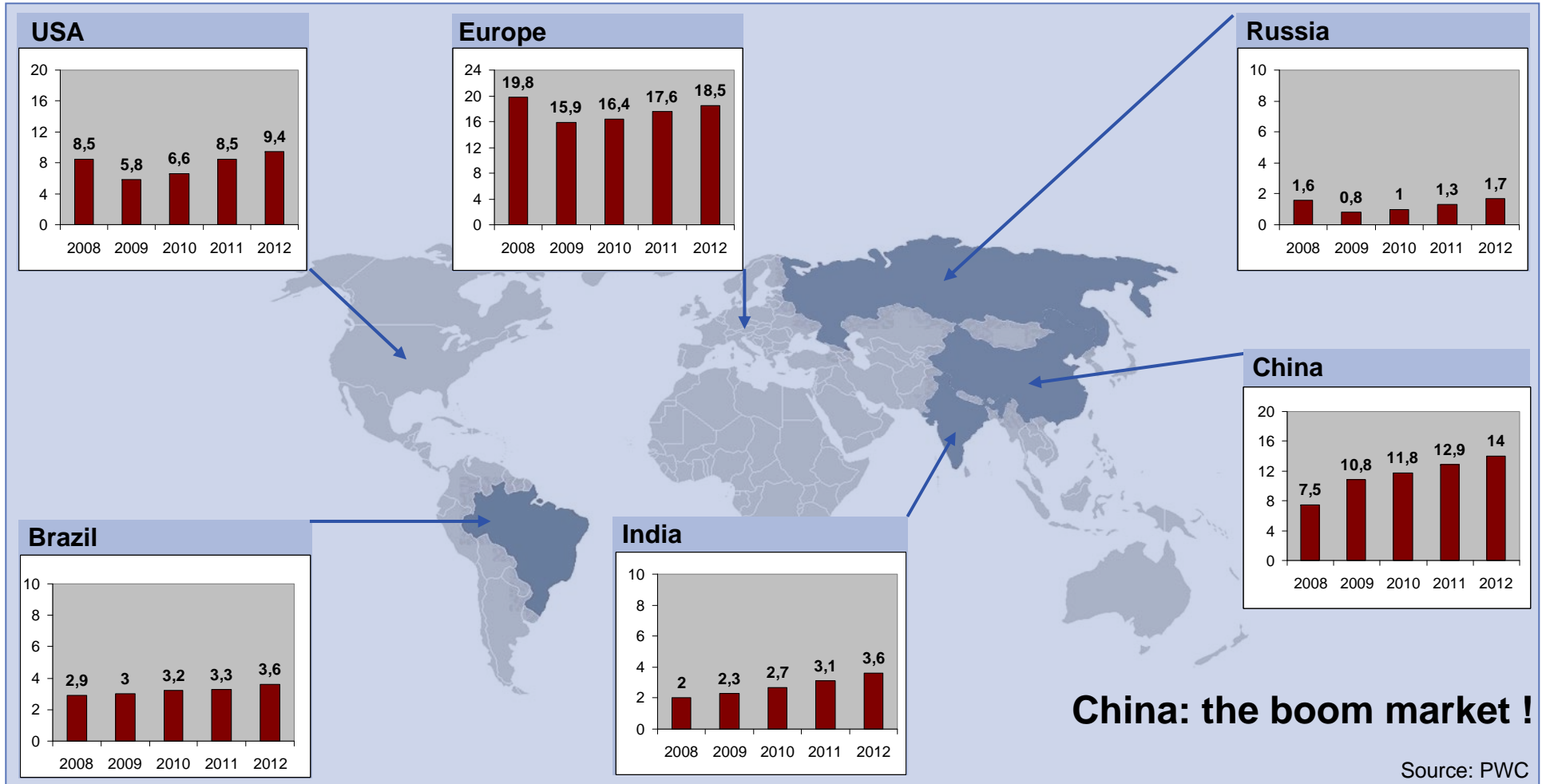

Incoming Orders and Sales Structure: Q1 2010 (Q1 2009)



**Incoming orders
Q1 2010 (Q1 2009)**

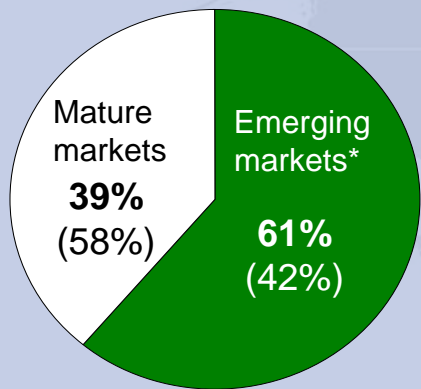

**Incoming orders
Q1 2010 (Q1 2009)**

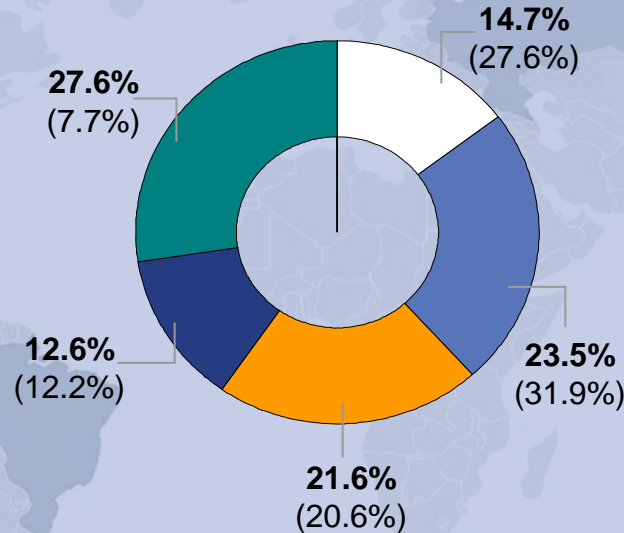

**Sales revenues
Q1 2010 (Q1 2009)**

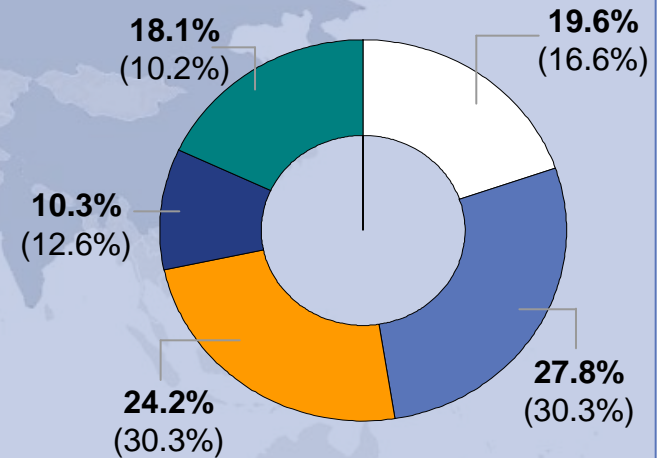

- Germany
- Europe excl. Germany incl. Eastern Europe
- North and South America
- Asia excl. China, Africa, Australia
- China

Emerging markets in the drivers seat !

*Asia (excl. Japan), Mexico, Brazil, Eastern Europe

Automotive Market and Car Manufacturing

Global trends and targets

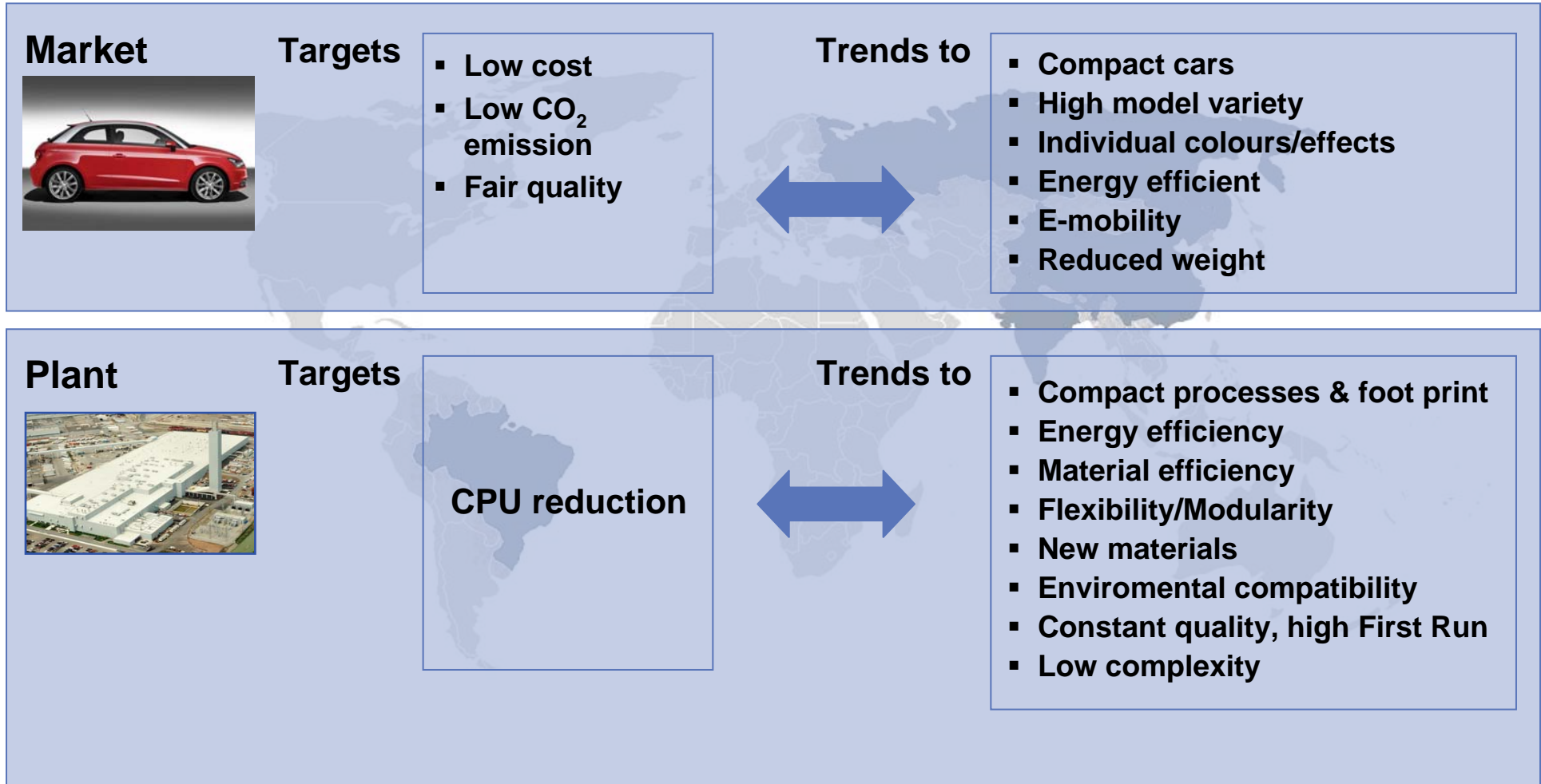

CPU: Established vs. Emerging Markets

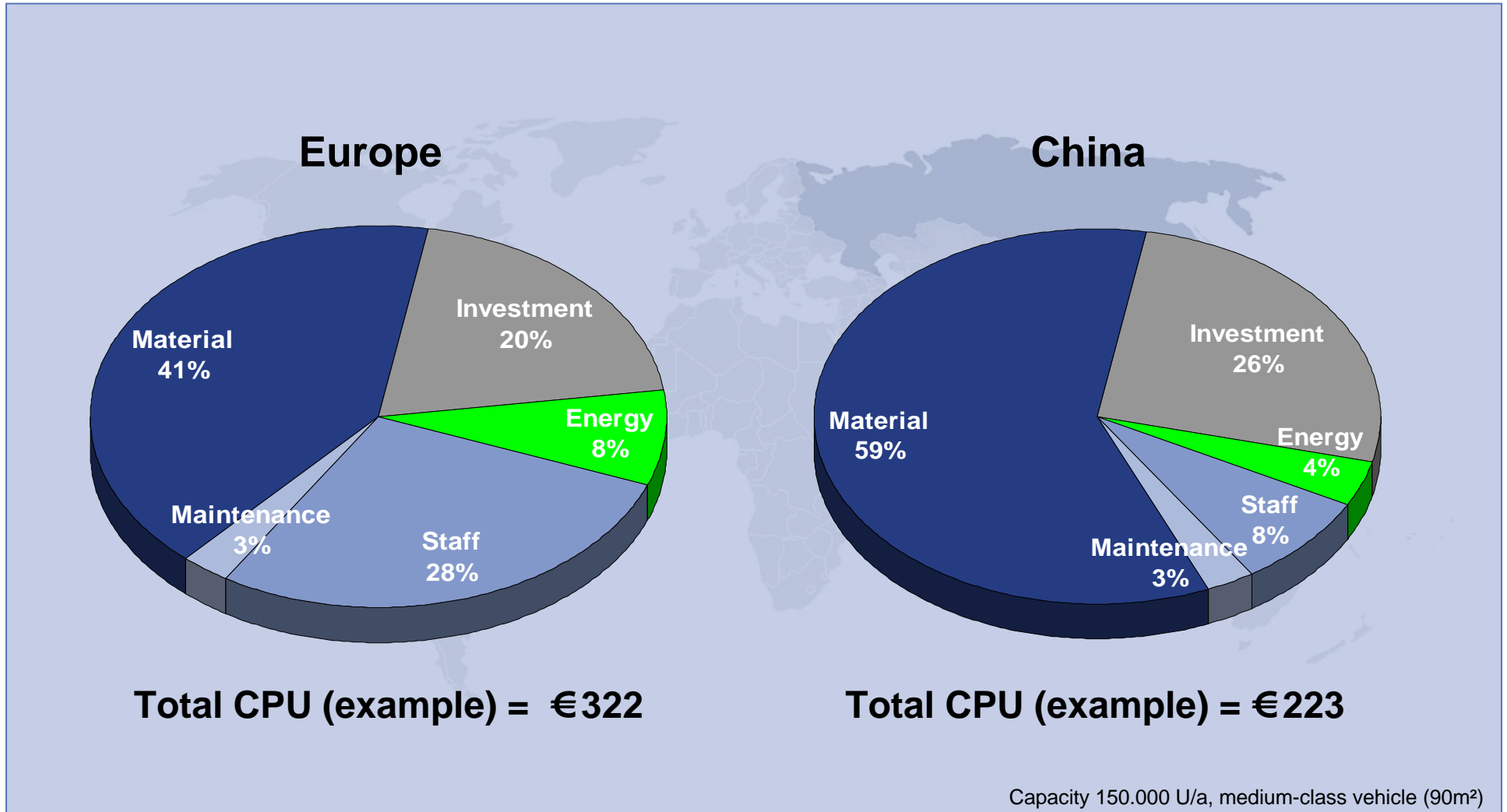

Paint Processes: Overview and Trends

Standard

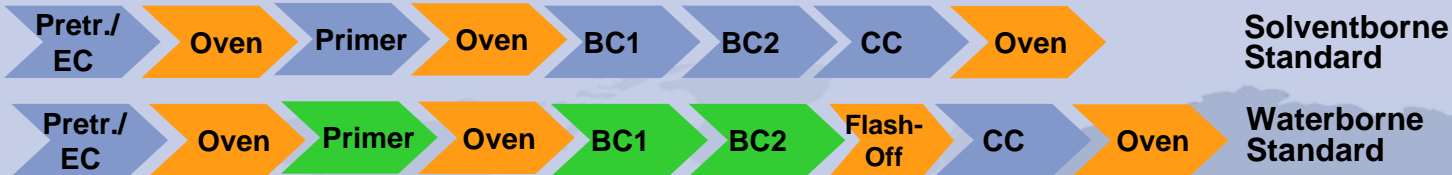

Compact

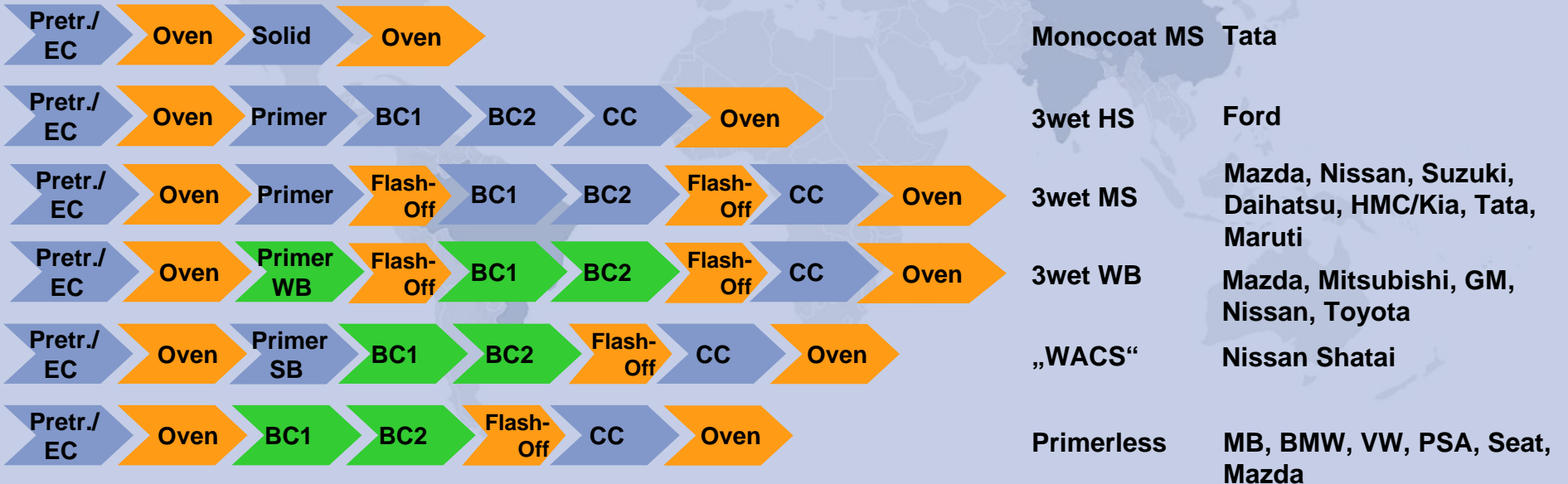

WACS: Water Absorbing Coating System

Paint Processes Trends

Attempt of an Evaluation

	SB Std.	WB Std.	3wet HS	3wet MS	3wet WB	Primer-less
Total line length, total processing time	○	●	●	○	●	●
Process window, need for automation	●	○	●	●	●	●
Body shop and E-Coat requirements	●	●	● ○	● ○	● ○	○
Environmental compatibility (VOC), w/o RTO	●	○	○	●	○	●
Energy consumption w/o DryScrubber	○	●	●	○	●	●

Paint Material Trend



Global Processes per OEM	Primer	Base Coat	Clear Coat
	BMW	●	●
Chrysler	● ●	●	●
Daimler	●	●	● 2K
Fiat	●	●	●
Ford	● HS	● ● HS	● HS
GM	● ●	●	● 1K/2K
PSA	● ●	●	● 1K/2K
Renault	●	●	●
VW	●	●	● 2K
HMC/Kia	● ●	● ●	● 1K/2K
Honda	● ●	● ●	● 1K/2K
Nissan	● ●	● ●	● 1K/2K
Toyota	● ●	● ●	● 1K/2K
Tata	●	●	●

Paint Automation Trend



Global Processes per OEM		Robots Exterior	Robots Interior	Bell/Bell	Bell Interior
	BMW	●	●	●	●
	Chrysler	●	●	●	●
	Daimler	●	●	●	●
	Fiat	●	●		
	Ford	●	●	●	●
	GM	●	●	●	●
	PSA	●	●	●	●
	Renault	●	●	●	●
	VW	●	●	●	●
	HMC/Kia	●	●	●	●
	Honda	●	●	●	●
	Nissan	●	●	●	●
Toyota	●	●	●	●	
Tata	●		●		

Top 10 Car Producers in China



	Compact Process	WBC Material	Robots Exterior	Robots Interior	Bell/Bell Exterior	Bell Interior
FAW - VW	●	●	●	●		
SVW	●	●	●	●		
ChangAn - Ford	●		●		●	
Hyundai	●	●	●		●	
SGM		●	●		●	
Toyota	●	●	●		●	
Honda	●	●	●		●	
Nissan	●	●	●		●	
Chery		●	●		●	
FAW		●	●		●	

- Global trends
- **Actual examples**
- Global solutions for efficient use of energy and resources

Mercedes Benz Kecskemét, Hungary



Project Highlights

- Rotational dip painting
- Compact primerless process
- Overspray dry separation for energy reduction
- High TE through Bell/Bell and Bell interior application
- Flexible, efficient sound deadening by LASD

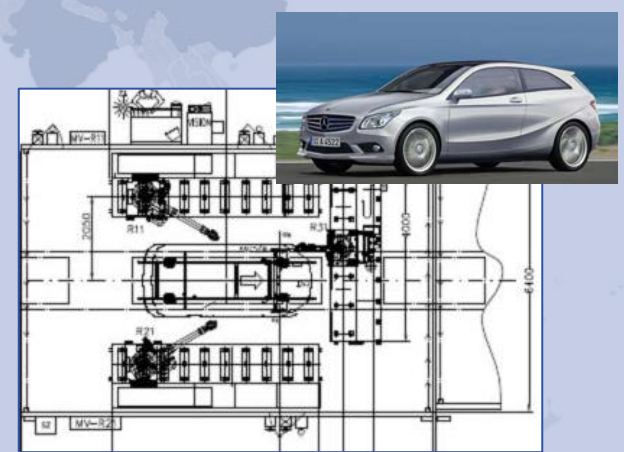
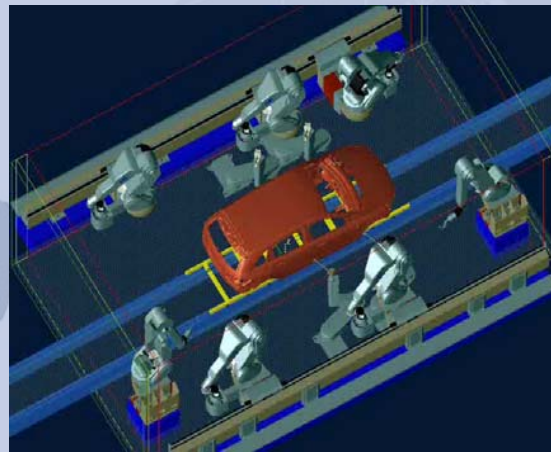

- Capacity: 30 U/h
- Exterior appl.: tracking
- Interior appl.: stop&go
- SOP: 01.02.2012

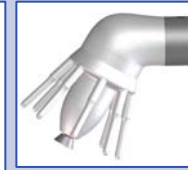

Tata Sanand, India



Project Highlights

- 2-Line-Concept (3wet line for „Nano luxury“, monocoat line for „Nano standard“)
- Rotational dip painting for high quality and compact plant
- Robot application for exterior areas
- Bell/Bell application for highest TE
- Colour change system with minimized paint loss (ICC)

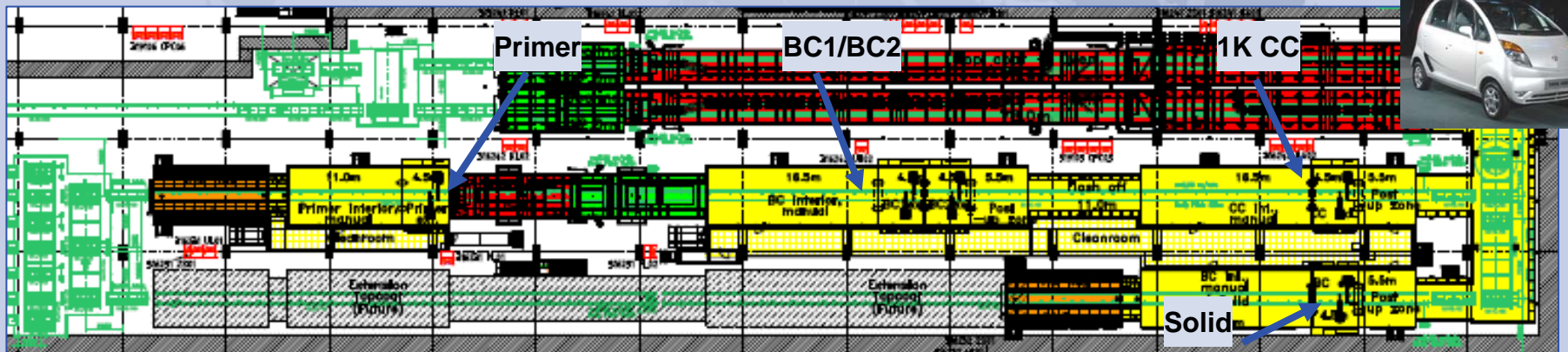

- Capacity: 60 U/h
- Application: tracking
- SOP: 01.06.2010

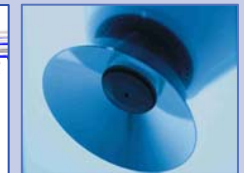
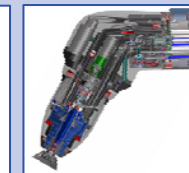

Chery Dalian, China



Project Highlights

- Rotational dip painting for high quality and compact plant
- Overspray dry separation for energy reduction
- Bell/Bell application for highest TE
- First Chery plant with robots for sealing application due to the high quality requirements

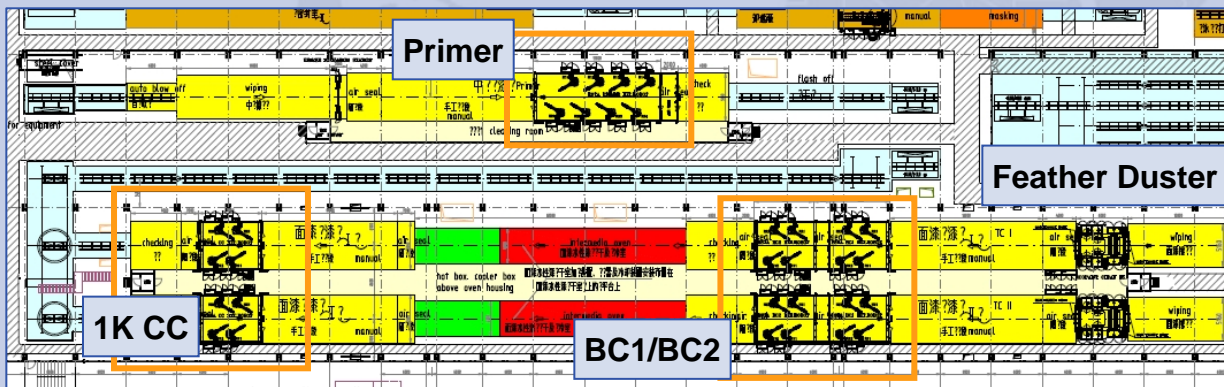

- Capacity: 60 U/h
- Application: tracking
- SOP: 01.10.2011

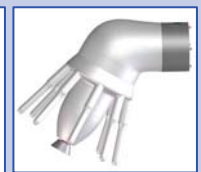

FAW-VW Chengdu, China



Project Highlights

- Rotational dip painting for high quality and compact plant
- Overspray dry separation for energy reduction
- Compact primerless process
- First plant with robots for interiors in China
- Colour change system with reduced paint loss (LCC)
- Contactless film thickness measuring system

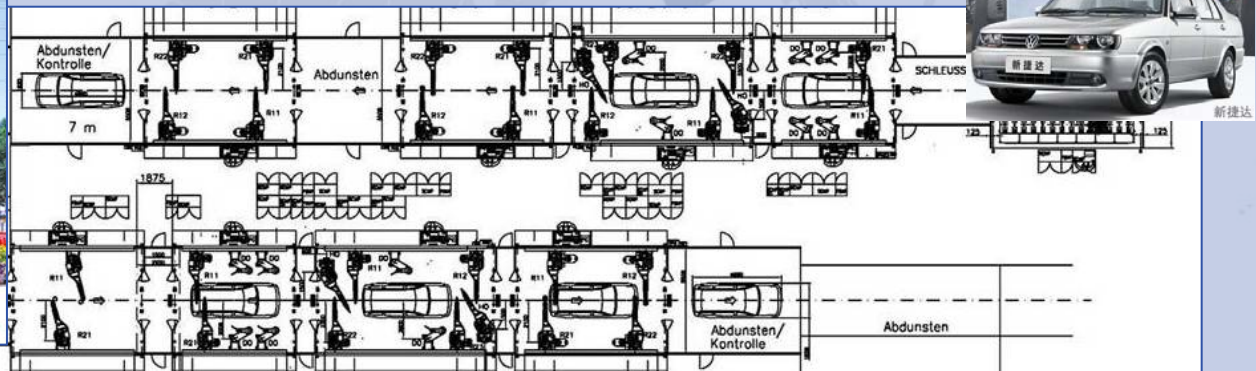
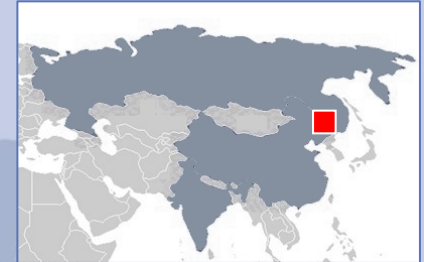

- Capacity: 62 U/h
- Exterior appl.: stop&go
- Interior appl.: stop&go
- SOP: 01.08.2011



VW Chattanooga, USA



Project Highlights

- Rotational dip painting
- Overspray dry separation for energy reduction
- Compact primerless process
- Colour change system with reduced paint loss (LCC)
- Contactless film thickness measuring system

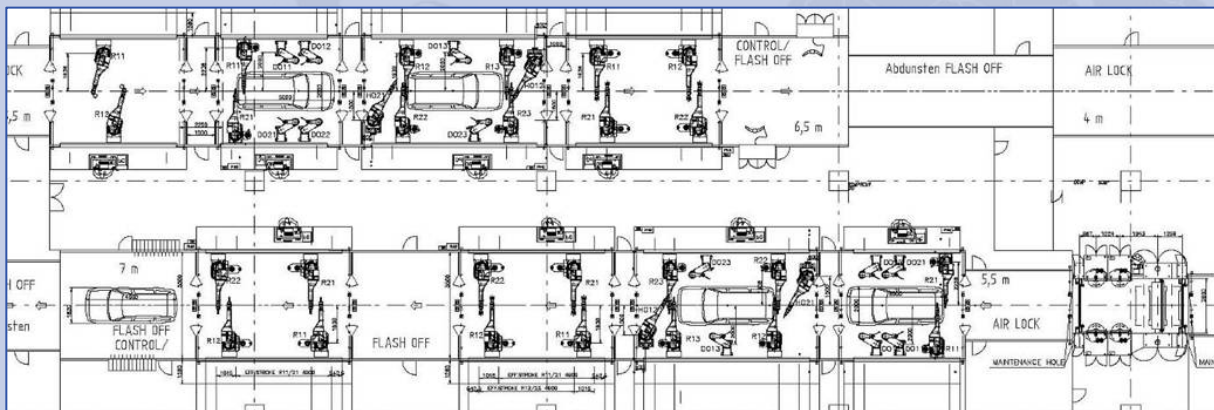
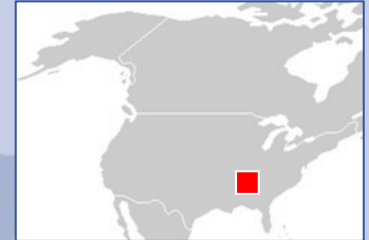

- Capacity: 38 U/h
- Exterior appl.: stop&go
- Interior appl.: stop&go
- SOP: 01.12.2010

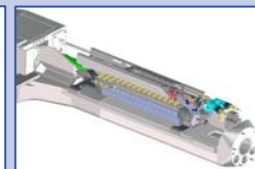

BMW Spartanburg, USA



Project Highlights

- Rotational dip painting for high quality and compact plant
- Compact primerless process
- Bell/Bell (partly Bell/Air) and Bell interior application with direct charge (Cartridge System)
- Contactless film thickness measuring system

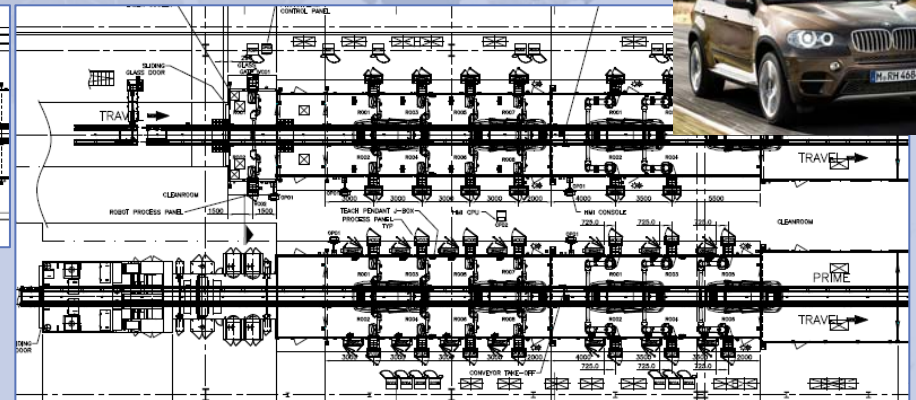
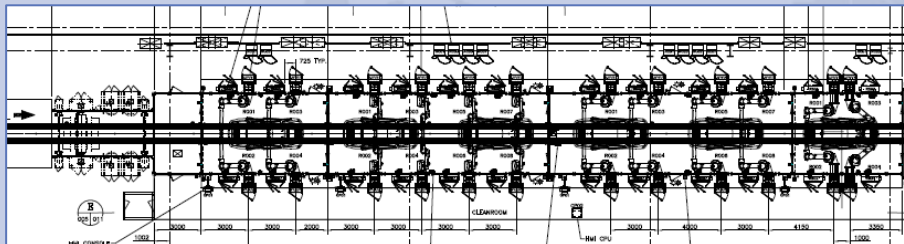

- Capacity: 35 U/h
- Exterior appl.: tracking
- Interior appl.: tracking
- SOP: 2009



Ford Cuautitlan, Mexico



Project Highlights

- 3wet high solid process
- Best ratio for line length vs. line output (68 m / 53 U/h)
- Full degrade mode for exteriors and interiors
- No manual back-up zones
- Bell/Bell and Bell interior application for highest TE

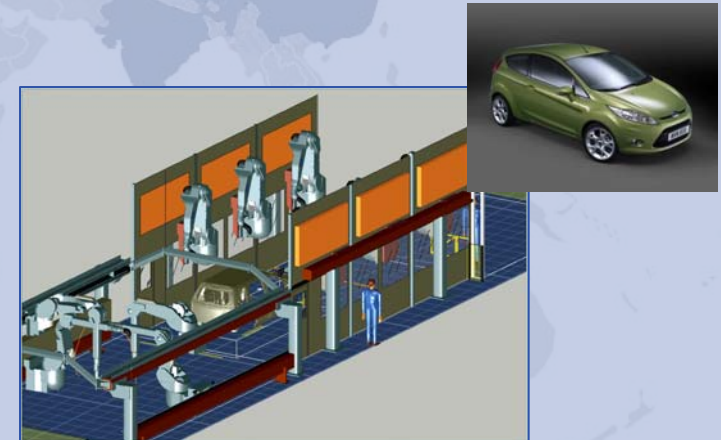
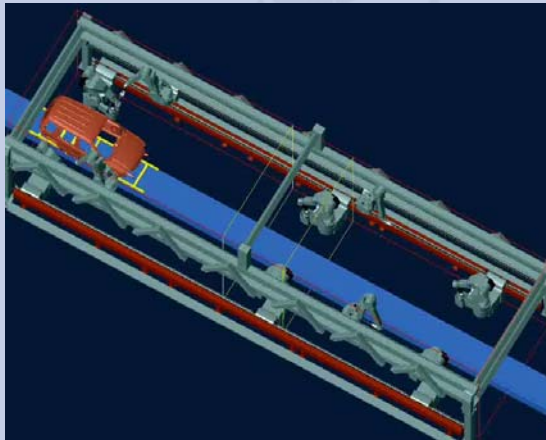

- Capacity: 53 U/h
- Application: tracking
- SOP: October 2009



Rehau Viechtach, Germany & Port Elizabeth, SA



Project Highlights

- Compact primerless process
- First installation of overspray dry separation for efficient energy use
- Movable paintshop out of the box
- Bell/Bell application for highest TE

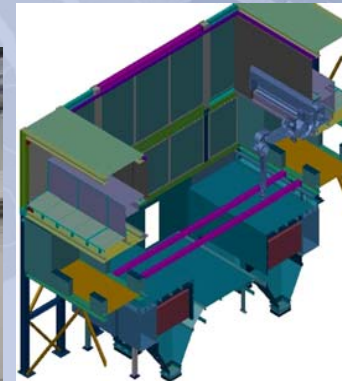

- Capacity: 150 U/h
- Cycle time: 24 sec
- Application: Tracking
- SOP: October 2008/July 2009

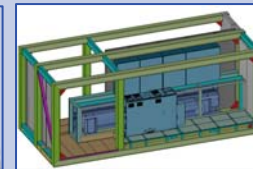

DFL Nissan Huadu, China



Project Highlights

- 3wet medium solid process
- Overspray dry separation for efficient energy use
- Bell/Bell application for highest TE
- One Bell type for all process steps

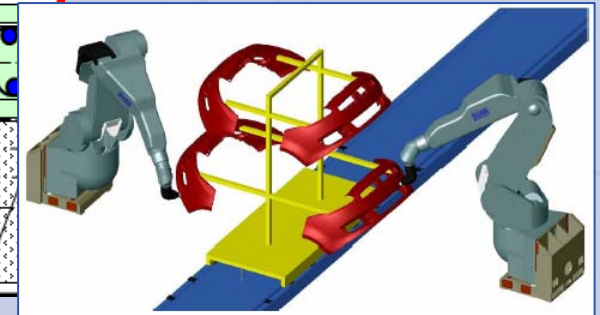
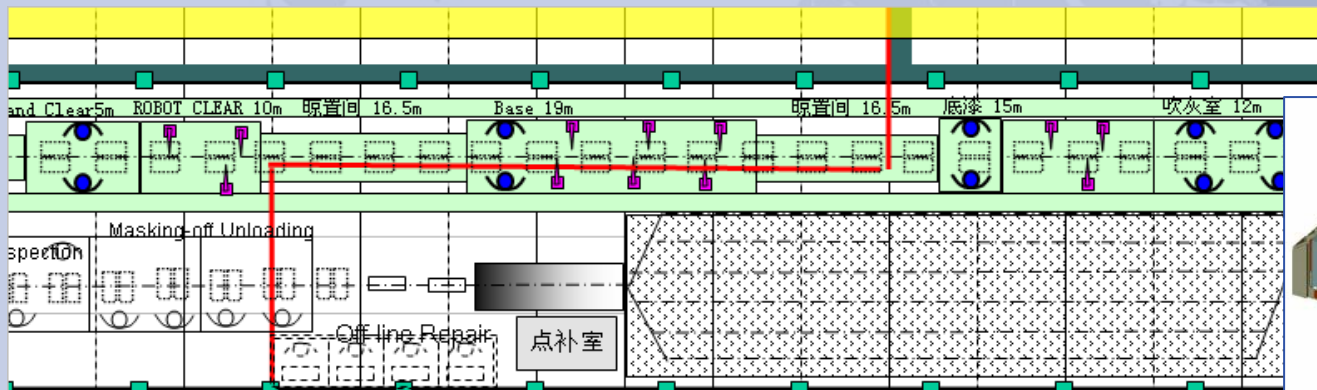
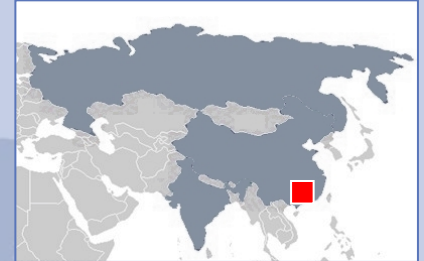

- Capacity: 160 U/h
- Cycle time: 48 sec
- Application: tracking
- SOP: November 2011



Porsche Stuttgart, Germany



Project Highlights

- New application technology with external charge atomizer for interiors & exteriors
- Interior and exterior application in same zone, footprint reduction
- Colour change system with reduced paint loss (LCC)
- Cleaning robots for highest flexibility and quality

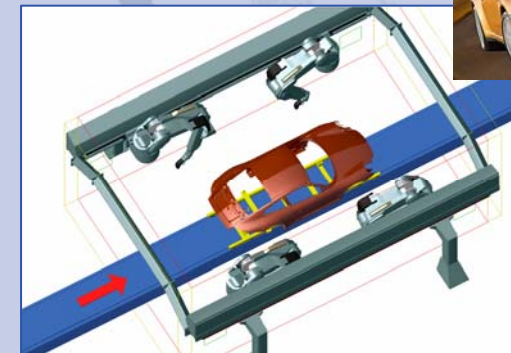
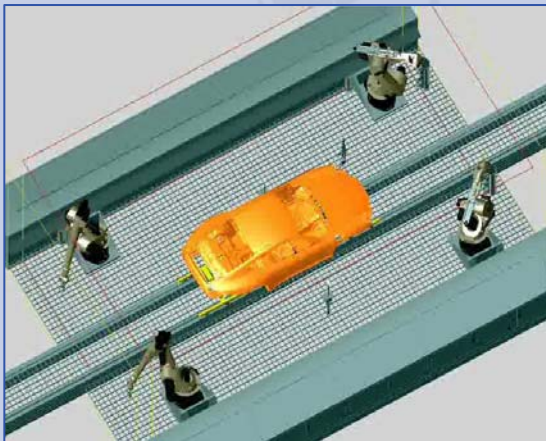

- Capacity: 16 U/h
- Exterior/interior application: stop&go
- SOP: April 2011

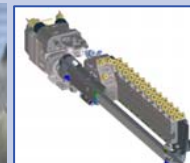

- Global trends
- Actual examples
- **Global solutions for efficient use of energy and resources**

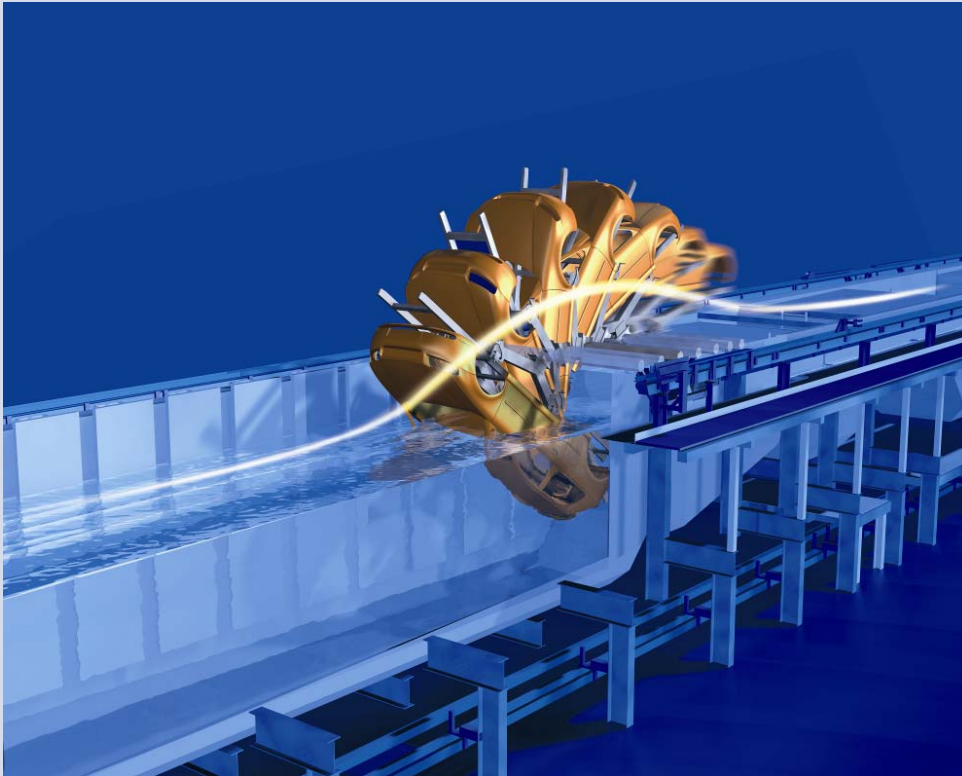

- CPU reduction up to 16%
- Simple, flexible and robust
- High quality due to the 360° rotation
- Optional electrical and mechanical variants and variant with additional vertical axis
- More than 18 million coated bodies with RoDip

***Ecopaint* RoDip: more flexibility and higher quality**

EcoDryScrubber



Overspray dry separation: the technology of the future



- CPU reduction: around 10 € per car body, energy savings up to 30%
- Dry overspray separation system for wet paints
- Automated separation of overspray without water and chemicals
- Effective recirculation of process air
- 35% reduced cross section

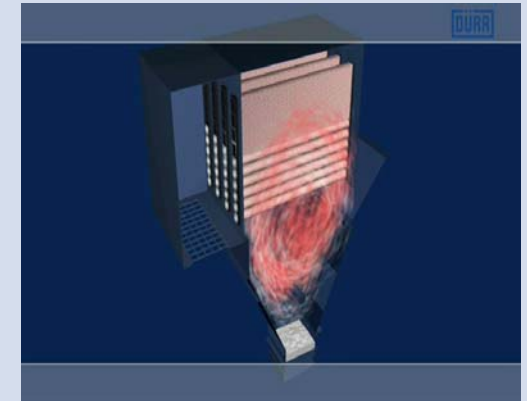

Already 15 orders received i.e. Daimler (Hungary), FAW/VW (China), Nissan (China), VW (USA), Rehau (Germany), Rehau (South Africa)

The new solution for waterborne paint application

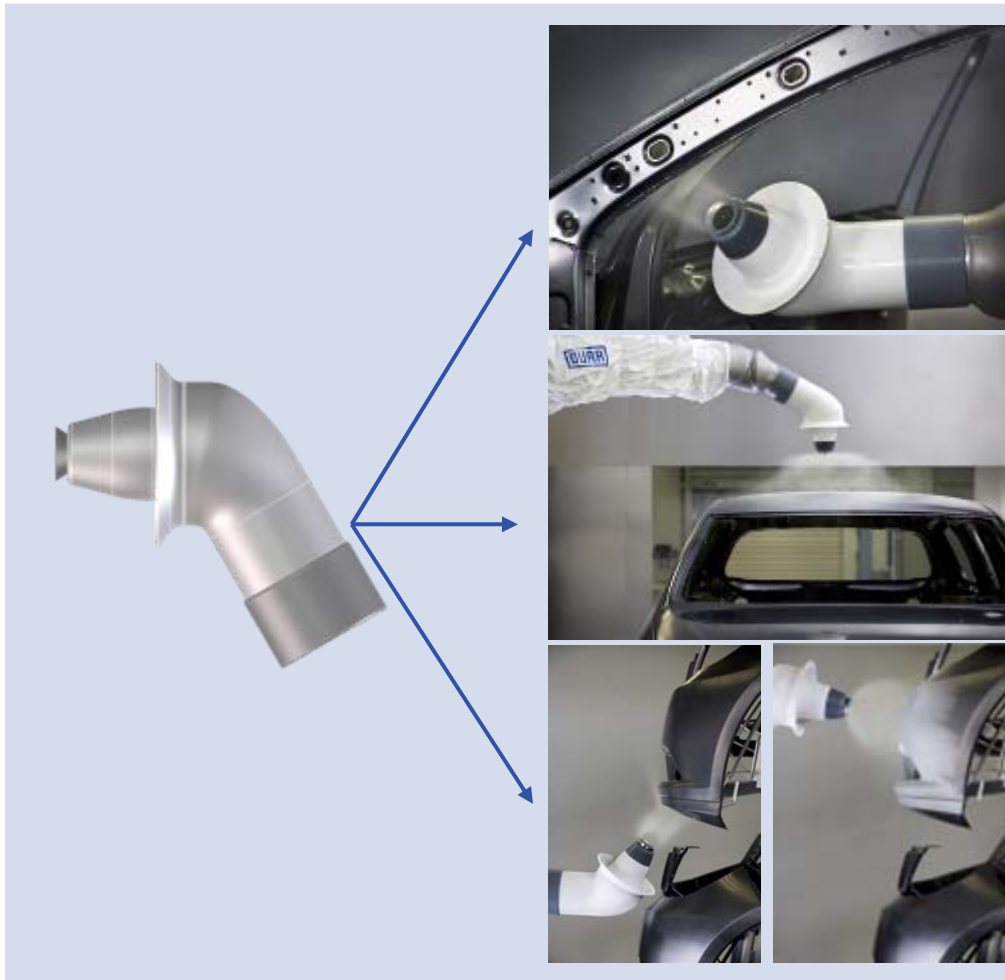

- Highest performance for exterior, interior and bumper painting
- Lowest system complexity
- No more voltage block
- Optimal accessibility due to the compact dimensions

Orders received: Porsche, Rehau, VW, Daimler Trials with different customers, e.g. VW, Volvo, Plastic Omnium, Decoma

EcoBell3: Overall System

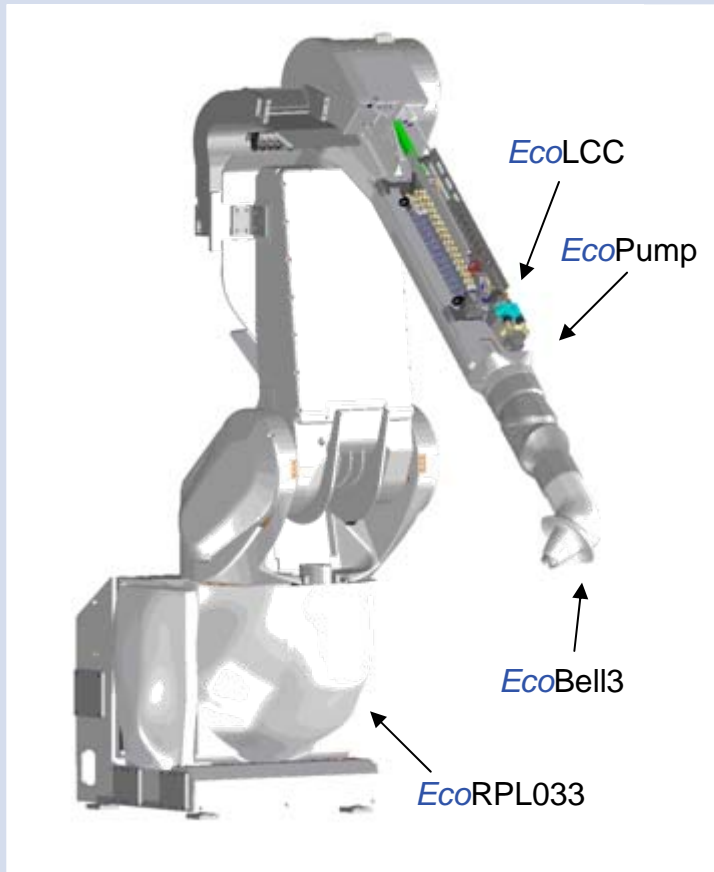

- Integration of all paint application equipment in the paint robot
- Smallest arm 2 by use of **EcoLCC** and **EcoPump** for colour change and dosing
- Reduction of colour change losses up to 10 ml
- Reduction of colour change time up to 10 sec

EcoBell3 and EcoLCC: Simple and compact overall system design

Conclusion

A faint, light blue world map is visible in the background of the slide, showing the outlines of continents and countries.

Efficient use of energy and resources...

...guaranteeing the future through sustainable solutions.