

Ecopaint Gluing

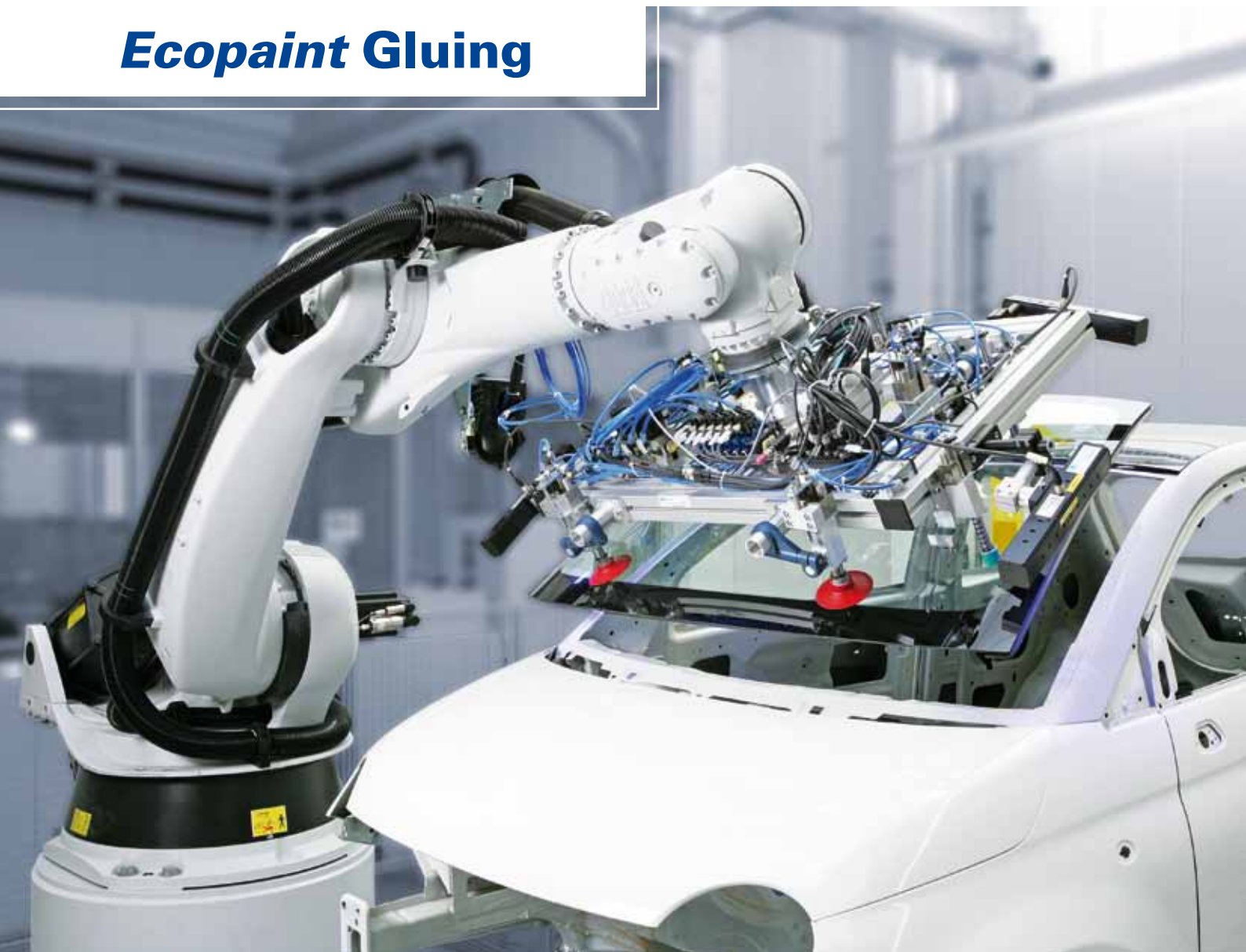

Gluing in Final Assembly



Technologies · Systems · Solutions

***Ecopaint Gluing* – Gluing in Final Assembly**



Window gluing

Processes and Products from Planning through Realization

The requirements on safety and convenience with automobiles are continuously increasing; simultaneously the market demands lower production and operating costs. As a supplier of turnkey installations for automated gluing in the final assembly, Dürr has comprehensive process knowledge and offers high-quality products that use the savings potentials already in the production and in addition lower the fuel consumption.

The innovative solutions of the ***Ecopaint Gluing*** series are based on know-how and experience from more than 500 robot installations for the application of highly viscous materials that were carried out successfully in the last years. This safeguards the quality and efficiency of your gluing processes in all fields of application. ■■■■■

The Advantages at a Glance:

- **Reduction of Unit Costs**
Automated processes for installation and glue application reduce the cycle time and unit costs. Simultaneously, error rates and post-treatment costs are decreased.
- **Maximum Quality**
Application systems of the ***Ecopaint Gluing*** product range ensure an optimum, reproducible process control and thus a constant quality of the gluing application. All decisive parameters for safety-relevant gluing are documented to 100 %.
- **Reduction of the Exposure of the Worker**
Automated solutions reduce the physical exposure when handling components and avoid the direct contact with hazardous materials.

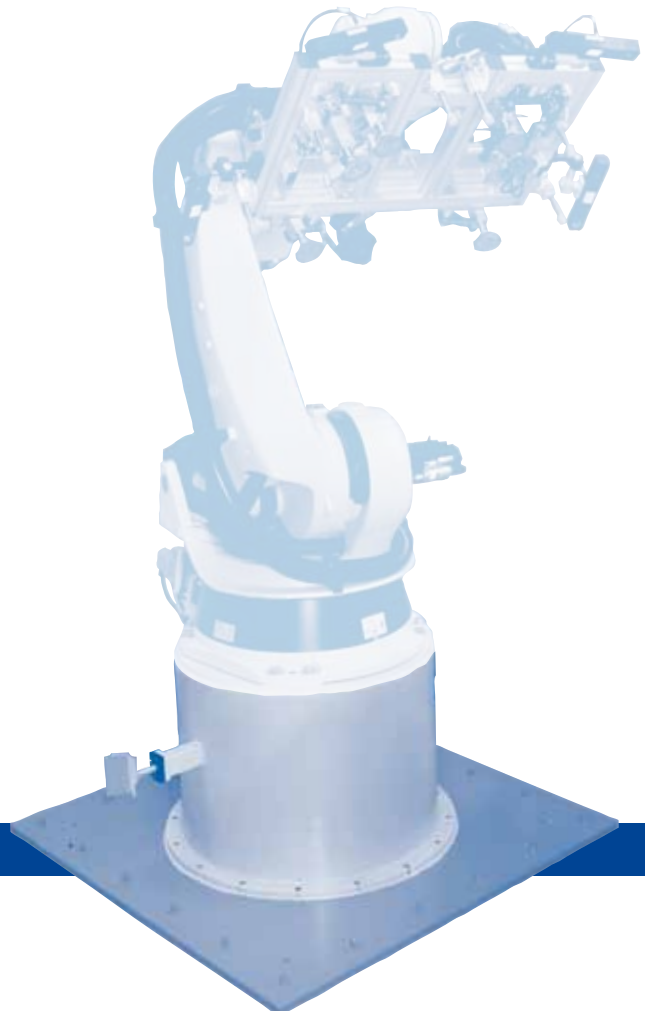

Process Optimization for Every Field of Application

Ecopaint Gluing offers solutions for all uses in final assembly and includes modular systems both for the glue application and for the installation of the components:

1. Window Glazing

Glued window panels improve the stability of the entire body and increase comfort and safety. In the last 20 years, windshield glazing has made a breakthrough with "Gluing" as the joining technology, and today it is regarded as state of the art. Here, glue is applied on the windows as a triangular bead and these are then inserted into the window section of the body.

2. Gluing of Roof Module

Automobiles with a modular design meet the requirements of individual customers and the objective of the manufacturers to lower the production times. Here, the modular design ensures a flexibility of the manufacturing processes. To keep the assembly expenditure as small as possible, preassembled components, for instance roof modules, are glued to the body with PUR glue. This way, it is possible to integrate module variants into the assembly process easily and without changes in the layout of the assembly line.

3. Gluing in Roof Reinforcement Dampings

Roof reinforcement dampings have a noise-reducing effect and increase comfort; at the same time they contribute to safety with their reinforcing function. For the gluing with the body, glue is applied in the shape of round and triangular beads.



Gluing of roof module

4. Cockpit installation

The cockpit is in part fixed to the bulkhead by means of combined screw/glue connections with condensation curing polyurethane glues. The installation is carried out in a fully or partially automated fashion and allows shorter cycle times.

5. Gluing of Further Modules (Plastic Module Installation)

Beyond the mentioned applications, plastic components, e.g. spare-wheel troughs or accumulator boxes, are glued into the body with moisture-curing 1K polyurethane or butyl caoutchouc glues in the final assembly. This contributes to the weight reduction of the vehicle and thus to the reduction of the fuel consumption.

Ecopaint Gluing – Gluing Processes during Final Assembly

The requirements of the automobile manufacturers on gluing cells are varying: quantities, labor costs and quality control requirements are decisive criteria for the layout of the gluing cells. The present state of the art offers automated and partially automated solutions for that. For the glue and surface pretreatment, Dürr offers robot-guided and stationary application solutions. ■■■■■■

Glue Application and Surface Pretreatment

Glue Application at the Robot – Mobile Applicator, Stationary Component

The robot-guided glue application comes frequently in combination with the manual installation of the components. In this concept, the glue is applied via automation on a stationary component which guarantees a high quality of the gluing bead.

Subsequent to the glue application, the component is installed manually. Compared with the fully automated concept, the amount of work is higher here and the quality of the installation is dependent on the worker.

However, the investment expenditures are smaller in this concept than with a fully automated installation concept.

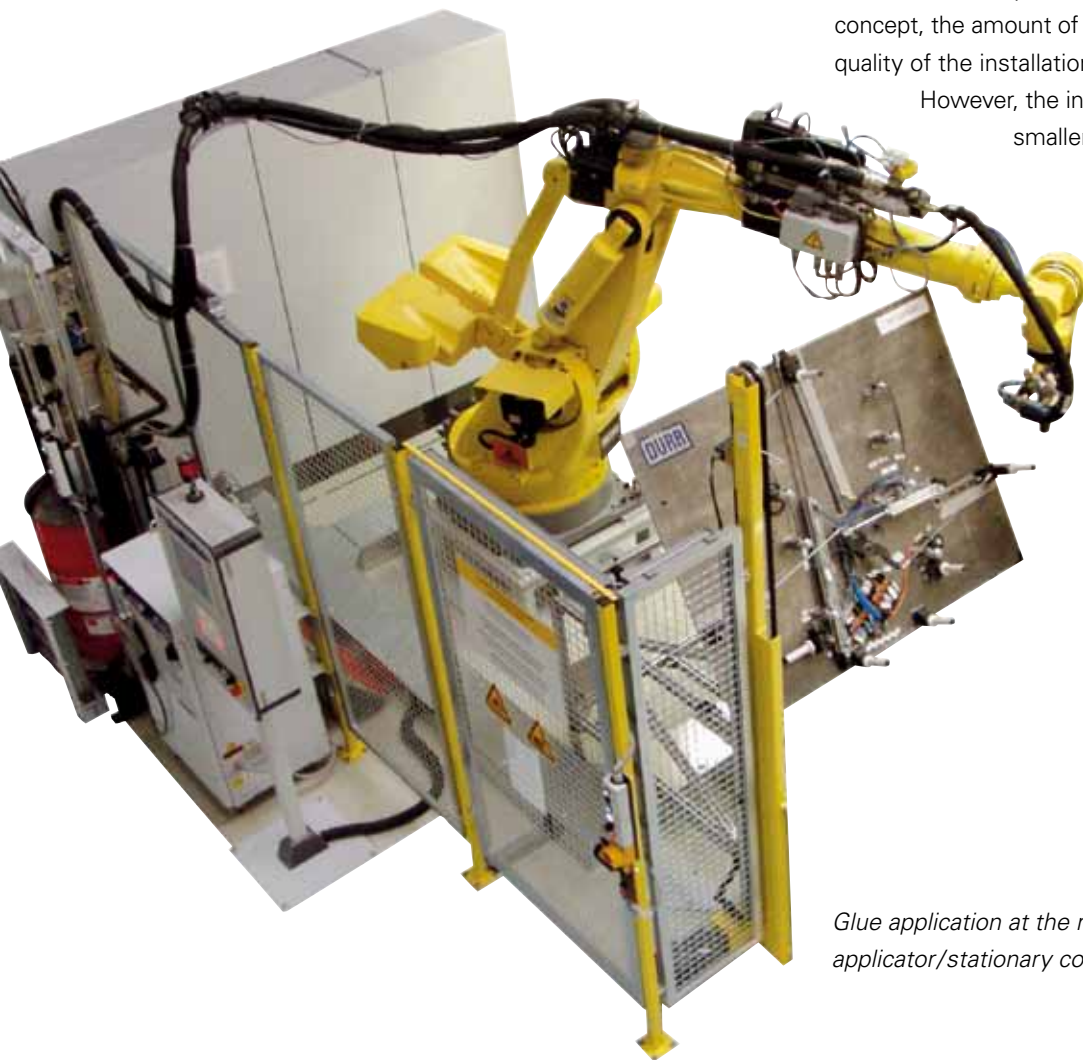

Glue application at the robot – mobile applicator/stationary component

Glue Application at the Tower – Stationary Applicator, Mobile Component

The concept of glue application on a component in motion is frequently used when the installation is carried out automatically with a robot. Here, the applicator is mounted stationarily to the gluing tower. For the glue application, the robot moves the component past the applicator and then the component is inserted into the corresponding body section. A vision system guides the robot.

Besides the advantages of the automatic glue application, the customer benefits from a higher and more consistent quality of the installation. The automation of the entire process reduces the amount of work. It is, however, combined with somewhat higher investment expenditures in comparison with the partially automated installation concept.

Surface Pretreatment – Application of Primer or Activator

The primer or activator application allows the production of durable glued connections due to an optimum surface pretreatment. With the **EcoGun Gluing N** and/or **S** applicators, it is possible to clean surfaces, to apply thin primer coats or to activate pre-primed window panels (robot-guided or stationary). For the application procedure of the primer, three application methods are available: spray, paintbrush or felt application. Optionally, Dürr offers the control of primer flow rate and application result. For the primer application, both a stationary solution at a primer tower and a robot solution are available. 

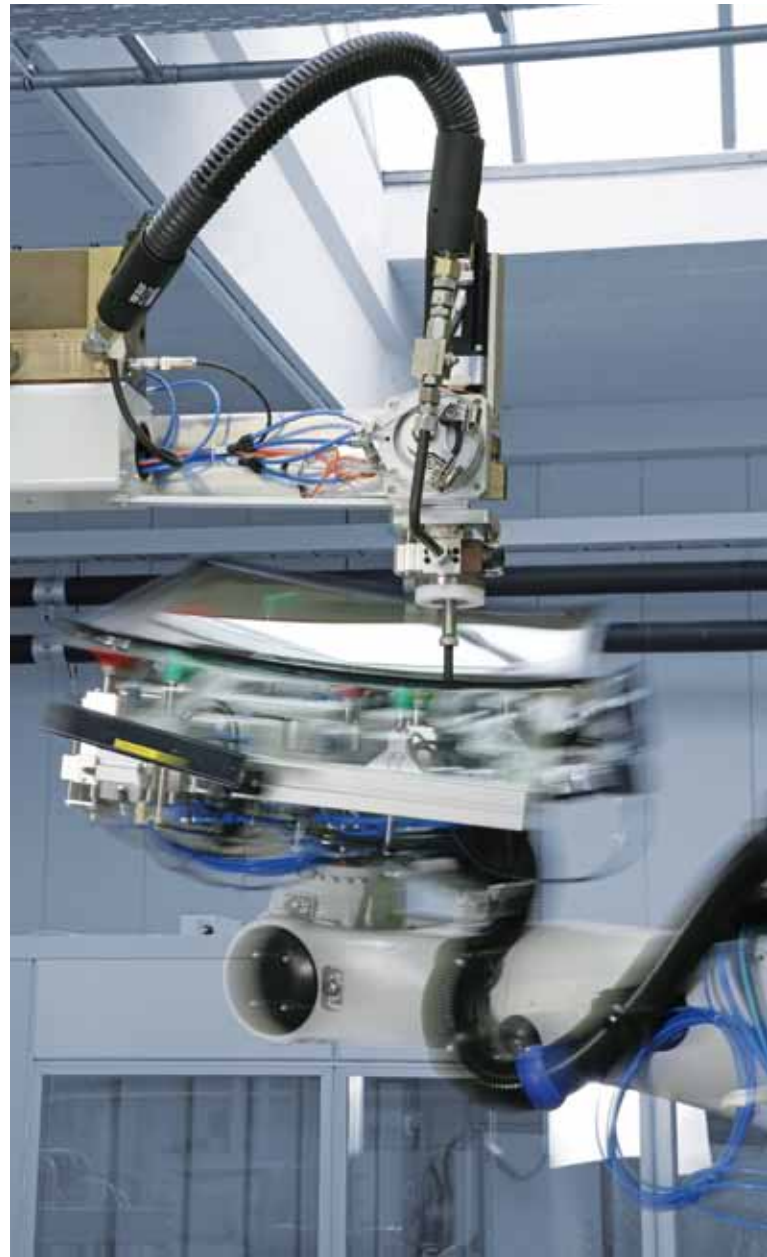

*Glue application at the tower –
stationary applicator/mobile component*

Ecopaint Gluing – Dosing and Material Supply

Dosing Device – *EcoShot* Meter for High Dynamics in the Process

Ecopaint Gluing piston dosing systems are volume-controlled dosing systems and meet all requirements on the optimum dosing of highly viscous glues.

With the **EcoShot Meter Single** electrical driven dosing device, the material is dosed continuously and extremely accurately. The system is suited for almost all applications in the final assembly where a large amount of highly viscous glues must be applied with high accuracy. For the dosing of the condensation curing glues on polyurethane basis that are frequently used in the final assembly, the dosing device has an optional connection for a blocking medium.

For the application of very large amounts, a double dosing device is available. The control of the dosing devices is fully integrated into the **EcoRPC** control and facilitates the application of continuous beads. The integrated hose breathing compensation achieves high dynamics and high accuracy of the dosing system. The dosing device has a modular design and is low-maintenance.

EcoShot Meter	
	EcoShot Meter Single
Mode of operation	<ul style="list-style-type: none"> • volume-controlled application • small to medium flow volumes
Dosing volume	110 ccm
Application pressure	up to 350 bar
Application tolerance	< 1 %
Material volume flow	up to 35 ccm/sec
Material temperature	up to 80 °C, heated
Reaction time	< 150 msec
Examples of ranges of application	<ul style="list-style-type: none"> • seam sealing • hemflange seams • door flange application • glue application



EcoShot Meter Single dosing device in installation position



EcoShot Meter Single	EcoShot Meter Double
<ul style="list-style-type: none"> • volume-controlled application • high volume flows 	<ul style="list-style-type: none"> • volume-controlled application • high volume flows • endless dosing
600 ccm	2 x 110 ccm
up to 350 bar	up to 350 bar
< 1 %	< 1 %
up to 35 ccm/sec	up to 35 ccm/sec
up to 80 °C, heated	up to 80 °C, heated
< 150 msec	< 150 msec
<ul style="list-style-type: none"> • sound deadener application • glue application 	<ul style="list-style-type: none"> • seam sealing • glue application

Barrel Pumps

Barrel pumps convey highly viscous media directly from the 200 liter original barrels to the dosing device. Depending on the necessary conveying volume, individual or double pumps are used. All pumps can be heated up to 80 °C.

The robust pneumatic piston pumps work with a pressure transmission of 65:1. The follow-up plates used for pressing the material out of the barrel are matched to the glue with regard to material and geometry. The pumps have a filling level and a "container empty" monitor, automatic disconnection and an automatic barrel changeover.

EcoHeat – Conditioning of the Material for Stable Application Results

The systematic preheating of the application materials prevents the process from being influenced by fluctuating material temperatures. This way, the material temperature remains constant in an optimal range for the application quality. The flow-controlled material dosing compensates an influencing of the application quality resulting from viscosity variations. **EcoHeat** for electrical material heating works in the temperature range of up to 80 °C. 

Ecopaint Gluing – Applicators for Perfect Quality

EcoGun Gluing Applicators allow the application of highly viscous glues with varying bead cross sections. The high pressure application heads are available both for the non-contact application of cylindrical beads and also for the contact application of beads with a defined cross section (triangular beads). In the contact application of triangular beads, component tolerances are compensated for by a pneumatic system. The compact design allows an easy application, even in hard to access components.

To reduce the material quantity between needle valve and nozzle, the valves are integrated directly into the nozzle adaptor head. This safeguards an optimum quality at the bead beginning and end.

The applicator can be equipped with various **EcoJet Nozzles** that are adapted specifically to the project. The nozzles are easy to exchange.

Optionally, an optical monitoring of the bead can be integrated. 



EcoGun Gluing F Applicator EcoGun Gluing C Applicator

	EcoGun Gluing F	EcoGun Gluing C
Characteristics		
Operating temperature	up to 80 °C	up to 80 °C
Flow volume	up to 70 ccm/sec	up to 50 ccm/sec
Material pressure	300 bar	300 bar
Heating	yes	yes
Integrated sensor system	pressure, temperature	pressure, temperature
Rotary feedthrough	no	yes, gear ratio 3:1
Z compensation	no	+/- 10 mm
Measures and weights		
Cross section valve block	40 mm x 40 mm	80 mm (diameter)
Weight	0.3 kg	approx. 14.5 kg

EcoGun Gluing Cleaner – Fully Automatic Nozzle Cleaning

To avoid the soiling of components, the **EcoGun Gluing Cleaner** cleans the nozzle of the applicator as required. A cleaning cloth automatically removes the gluing material from the application nozzle. The **EcoGun Gluing Cleaner** is suitable for all nozzle geometries and can either be installed to the **EcoJet Nozzle** in either a stationary or mobile fashion.

The **EcoGun Gluing Cleaner** guarantees the cleanness of the components, does not use any compressed air, is easy to maintain and noiseless.

Gluing Tower – Carrier of Dosing Device and Applicator

The gluing tower is used for the application-specific arrangement of the dosing device and applicator in the gluing processes. The stiff design that is optimized with regard to vibrational energy and the short distance between dosing device and applicator ensure an exact application result. Flexibly adjustable in height, boom length and application angle, it facilitates the adaptation to spatial and project-specific requirements. The modular design of the lightweight steel structure allows not only the adaptation to spatial requirements, but also the customer-specific flexible layout. With the optionally available, vertically traveling axis, the entire application technology is brought into a position that is easy to maintain. The same traveling unit also offers the possibility to move the nozzle into the also optionally available nozzle cleaning device at the tower and to clean it there.

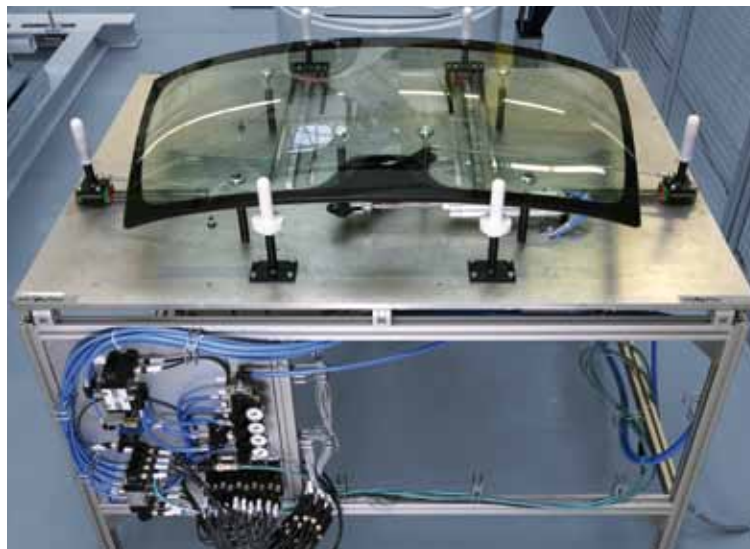

Centering table



EcoGripper – gripper with window pane

Centering Table – Optimum Alignment of Windows

Low-tension centering is used for the positioning and direction of the window before it is guided to the following primer or glue application in the robot-guided process. The window panel recognition and, where appropriate, a type recognition is carried out by a capacitive sensor. Sensors also check the function of the centering elements. The centering table is optionally available in a tiltable execution for the ergonomic inserting of components.

EcoGripper – Grippers for Low-Deformation Handling of Components

During the glue application and in the installation, vacuum sucking grippers with a vision system handle the windows and roof modules. An automatic adaptation of the suction device position allows the low-deformation handling of the component and in this way minimizes resilience after its installation. The standardized modules of the gripper are suited for the adaptation of various component sizes. Its fastening to a flexible aluminum profile construction allows the easy adaptation to various component geometries. The exchangeability of individual system sections makes the **EcoGripper** especially easy to maintain. Furthermore, the aluminum elements reduce the weight and provide easy mounting options for further add-on parts, such as the cameras of the vision system.



Gluing tower

Ecopaint Gluing – Robot Stations for All Application Processes

EcoRS – Efficient Robotics Technology

For specific job definitions and requirements, robots are available in various sizes and with various loads. The desired degree of automation and the individual space available in the gluing cell determine type, scope and arrangement of the robots.



The Dürr **EcoRS** robot controller integrates movement and process control on one platform. This increases the application quality compared with non-integrated systems and optimizes the material consumption.

A homogeneous design for the control, operating concept and user interface with the gluing, sealing and painting applications facilitates the handling of the robots in the factory.

EcoRPC – Integrated Robot and Process Control

EcoRPC controls the processes for gluing, sealing and painting applications and offers the following advantages:

- motion-kinematic/multiprocess ability with up to four movement/process units
- integrated PLC system for easy diagnosis and adaptation of process and automation functions
- easy maintenance

EcoRS		
	EcoRS60	EcoRS210
		
Application	Robot-guided gluing application	Component handling
Load-bearing capacity at the hand axis	60	210
Weight (kg)	635	1267
Max. range (mm)	2033	2700
Workspace (mm)	2033	2700
Repetitive accuracy (mm)	+/- 0.20	+/- 0.12
Payload at the arm (kg)	35	50/100/350

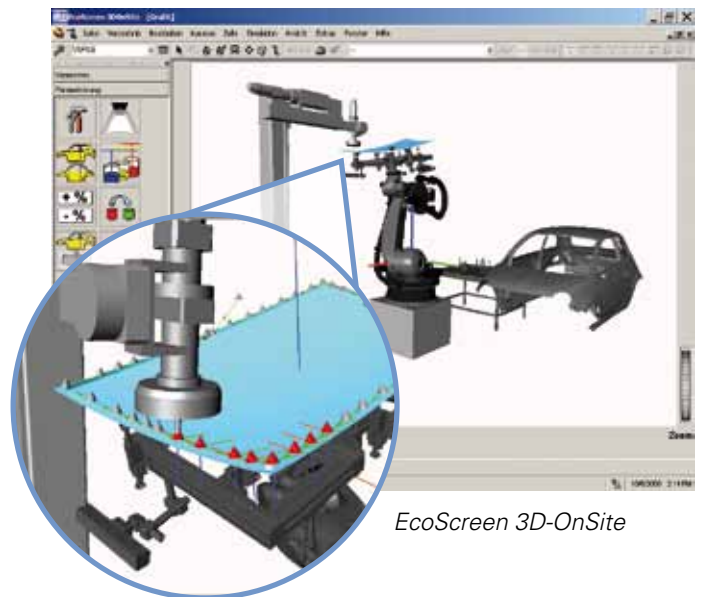

EcoScreen 3D-OnSite

Ecopaint Testcenter Gluing

EcoScreen 3D-OnSite – 3D Vision and Programming Software

EcoScreen 3D-OnSite is a 3D visualization and programming software developed by Dürr that was designed for the production and processing of robot programs as well as the parameterization of the corresponding process data. This way, an optimum tool is available to the customer for the installation operation directly at the robot cell in the production line:

- change of path and process parameters are possible online and offline
- no downtimes due to online parameterization
- 3D robot cell with car body model
- simulation

Vision System for Robot Guiding

For the installation, the component is first of all positioned in front of the body section. A 3D image display system measures the body section to determine the installation position. Via robot and gripper, the component is inserted automatically into the body section, whereby the vision system guides the robot. After that, the gripper releases the window and its position in the body is measured once again to ensure the exact position and thus the quality of the window installation.

Optionally, the vision system can also be used to measure the windows before gripping, which considerably reduces the requirements on the centering process before the installation. 



Gluing cell in the Ecopaint Testcenter Gluing

The gluing cell in the **Ecopaint Testcenter Gluing** at the Dürr technology center for gluing material applications is available for component trials, product and process developments and the validation of new products. The test center represents a complete glue application and is equipped with:

- 6-axis robot
- gluing tower
- centering table
- window grippers
- dosing systems
- applicators for glue and primer application
- nozzle cleaning
- material supply
- optical measuring and monitoring systems

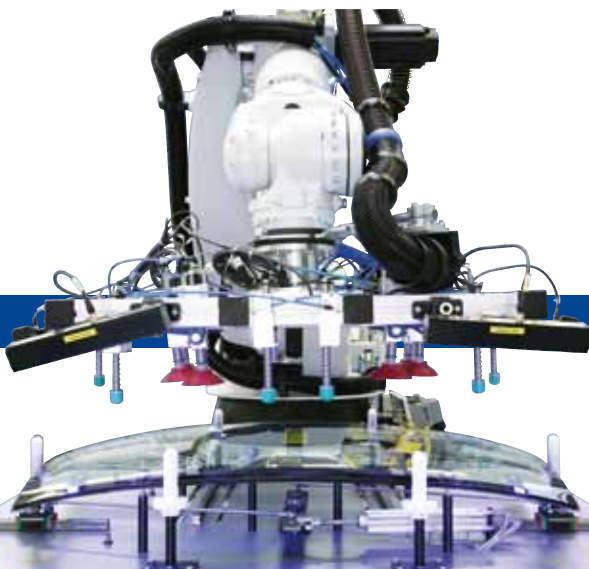

Vision System – measurement of the windows before gripping

Ecopaint Gluing

Your Competitive Advantage with Dürr:

- reduction of unit costs
- maximum quality
- reduction of worker exposure
- everything from one supplier – integrator with its own products synchronized with each other

Application Technology · www.durr.com



Technologies · Systems · Solutions